



JVC[®]

TENTATIVE

JVC[®]



DV CAMCORDER
DV CAMKORDER
CAMESCOPE DV

DV CAMCORDER

GY-DV300
Mini **DV**

INSTRUCTION MANUAL
BEDIENUNGSANLEITUNG
MANUEL D'INSTRUCTIONS

GY-DV300
Mini **DV**

INSTRUCTION MANUAL

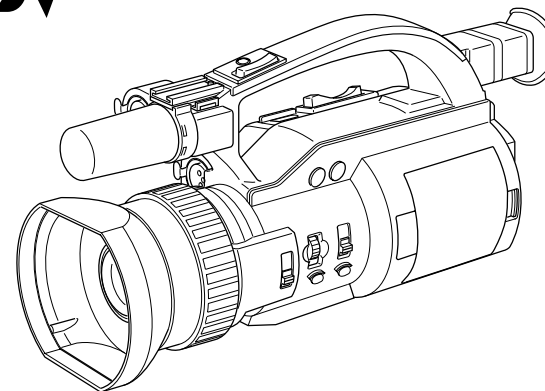
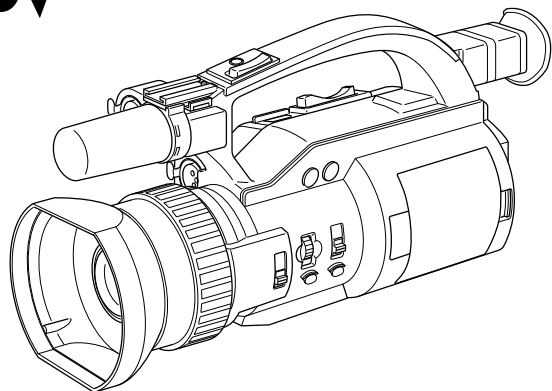

Thank you for purchasing this JVC product. Before operating this unit, please read the instructions carefully to ensure the best possible performance.

This instruction manual is made from 100% recycled paper.

Thank you for purchasing this JVC product. Before operating this unit, please read the instructions carefully to ensure the best possible performance.

For Customer Use :
Enter below the Serial No. which is located on the body.
Retain this information for future reference.
Model No. GY-DV300
Serial No. _____

This instruction manual is made from 100% recycled paper.



IMPORTANT SAFEGUARDS

1. Read all of these instructions.
2. Save these instructions for later use.
3. All warnings on the product and in the operating instructions should be adhered to.
4. Unplug this appliance system from the wall outlet before cleaning. Do not use liquid cleaners or aerosol cleaners. Use a damp cloth for cleaning.
5. Do not use attachments not recommended by the appliance manufacturer as they may cause hazards.
6. Do not use this appliance near water – for example, near a bathtub, washbowl, kitchen sink, or laundry tub, in a wet basement, or near a swimming pool, etc.
7. Do not place this appliance on an unstable cart, stand, or table. The appliance may fall, causing serious injury to a child or adult, and serious damage to the appliance. Use only with a cart or stand recommended by the manufacturer, or sold with the appliance. Wall or shelf mounting should follow the manufacturer's instructions, and should use a mounting kit approved by the manufacturer. An appliance and cart combination should be moved with care. Quick stops, excessive force, and uneven surfaces may cause the appliance and cart combination to overturn.
8. Slots and openings in the cabinet and the back or bottom are provided for ventilation, and to insure reliable operation of the appliance and to protect it from overheating, these openings must not be blocked or covered. The openings should never be blocked by placing the appliance on a bed, sofa, rug, or other similar surface. This appliance should never be placed near or over a radiator or heat register. This appliance should not be placed in a built-in installation such as a bookcase unless proper ventilation is provided.
9. This appliance should be operated only from the type of power source indicated on the marking label. If you are not sure of the type of power supplied to your home, consult your dealer or local power company. For appliance designed to operate from battery power, refer to the operating instructions.
10. This appliance system is equipped with a 3-wire grounding type plug (a plug having a third (grounding) pin). This plug will only fit into a grounding-type power outlet. This is a safety feature. If you are unable to insert the plug into the outlet, contact your electrician to replace your obsolete outlet. Do not defeat the safety purpose of the grounding plug.
11. For added protection for this product during a lightning storm, or when it is left unattended and unused for long periods of time, unplug it from the wall outlet and disconnect the antenna or cable system. This will prevent damage to the product due to lightning and power-line surges.
12. Do not allow anything to rest on the power cord. Do not locate this appliance where the cord will be abused by persons walking on it.
13. Follow all warnings and instructions marked on the appliance.
14. Do not overload wall outlets and extension cords as this can result in fire or electric shock.
15. Never push objects of any kind into this appliance through cabinet slots as they may touch dangerous voltage points or short out parts that could result in a fire or electric shock. Never spill liquid of any kind on the appliance.
16. Do not attempt to service this appliance yourself as opening or removing covers may expose you to dangerous voltage or other hazards. Refer all servicing to qualified service personnel.
17. Unplug this appliance from the wall outlet and refer servicing to qualified service personnel under the following conditions:
 - a. When the power cord or plug is damaged or frayed.
 - b. If liquid has been spilled into the appliance.
 - c. If the appliance has been exposed to rain or water.
 - d. If the appliance does not operate normally by following the operating instructions. Adjust only those controls that are covered by the operating instructions as improper adjustment of other controls may result in damage and will often require extensive work by a qualified technician to restore the appliance to normal operation.
 - e. If the appliance has been dropped or the cabinet has been damaged.
 - f. When the appliance exhibits a distinct change in performance – this indicates a need for service.
18. When replacement parts are required, be sure the service technician has used replacement parts specified by the manufacturer that have the same characteristics as the original part. Unauthorized substitutions may result in fire, electric shock, or other hazards.
19. Upon completion of any service or repairs to this appliance, ask the service technician to perform routine safety checks to determine that the appliance is in safe operating condition.

PORTABLE CART WARNING
(symbol provided by RETAC)



S3126A

Thank you for purchasing the JVC GY-DV300 Camcorder.

These instructions are for the GY-DV300E.

The instructions are given in three languages: English from page E-2 to E-107, German from page G-2 to G-107, French from page F-2 to F-107.

This equipment is in conformity with the provisions and protection requirements of the corresponding European Directives. This equipment is designed for professional video appliances and can be used in the following environments:

- residential area (in houses) or rural area
- commercial and light industry; e.g. offices or theatres
- urban outdoors

In order to keep the best performance and furthermore for electromagnetic compatibility we recommend to use cables not exceeding the following length:

Port	Cable	Length	Port	Cable	Length
DC IN	Exclusive Cable	1.9 meters	EARPHONE	Shielded Cable	1 meters
VIDEO OUT	Shielded Cable	5 meters	DV	Exclusive Cable	4.5 meters
Y/C OUT	Exclusive Cable	3 meters	MIC1	Shielded Cable	0.3 meters
LINE OUT CH-1CH-2	Shielded Cable	3 meters	MIC2	Shielded Cable	0.3 meters

Caution : Where there are strong electromagnetic waves or magnetism, for example near a radio or TV transmitter, transformer, motor, etc., the picture and the sound may be disturbed. In such case, please keep the apparatus away from the sources of the disturbance.

TENTATIVE



SAFETY PRECAUTIONS

FOR USA AND CANADA



CAUTION: TO REDUCE THE RISK OF ELECTRIC SHOCK, DO NOT REMOVE COVER (OR BACK). NO USER SERVICEABLE PARTS INSIDE. REFER SERVICING TO QUALIFIED SERVICE PERSONNEL.



The lightning flash with arrowhead symbol, within an equilateral triangle is intended to alert the user to the presence of uninsulated "dangerous voltage" within the product's enclosure that may be of sufficient magnitude to constitute a risk of electric shock to persons.



The exclamation point within an equilateral triangle is intended to alert the user to the presence of important operating and maintenance (servicing) instructions in the literature accompanying the appliance.

INFORMATION FOR USA

INFORMATION

This equipment has been tested and found to comply with the limits for a Class B digital device, pursuant to Part 15 of the FCC Rules.

These limits are designed to provide reasonable protection against harmful interference in a residential installation. This equipment generates, uses, and can radiate radio frequency energy and, if not installed and used in accordance with the instructions, may cause harmful interference to radio communications. However, there is no guarantee that interference will not occur in a particular installation. If this equipment does cause harmful interference to radio or television reception, which can be determined by turning the equipment off and on, the user is encouraged to try to correct the interference by one or more of the following measures:

- Reorient or relocate the receiving antenna.
- Increase the separation between the equipment and receiver.
- Connect the equipment into an outlet on a circuit different from that to which the receiver is connected.
- Consult the dealer or an experienced radio/TV technician for help.

CAUTION

CHANGES OR MODIFICATIONS NOT APPROVED BY JVC COULD VOID USER'S AUTHORITY TO OPERATE THE EQUIPMENT.

THIS DEVICE COMPLIES WITH PART 15 OF THE FCC RULES. OPERATION IS SUBJECT TO THE FOLLOWING TWO CONDITIONS : (1) THIS DEVICE MAY NOT CAUSE HARMFUL INTERFERENCE, AND (2) THIS DEVICE MUST ACCEPT ANY INTERFERENCE RECEIVED, INCLUDING INTERFERENCE THAT MAY CAUSE UNDESIRE OPERATION

INFORMATION (FOR CANADA) RENSEIGNEMENT (POUR CANADA)

This Class B digital apparatus complies with Canadian ICES-003.

Cet appareil numérique de la Class B est conforme à la norme NMB-003 du Canada.

WARNING:

TO REDUCE THE RISK OF FIRE OR ELECTRIC SHOCK, DO NOT EXPOSE THIS APPLIANCE TO RAIN OR MOISTURE.

This unit should be used with 7V DC only.

CAUTION:

To prevent electric shocks and fire hazards, do NOT use any other power source.

NOTE:

The rating plate (serial number plate) is on the body.

CAUTION

To prevent electric shock, do not open the cabinet. No user serviceable parts inside. Refer servicing to qualified service personnel.

AVERTISSEMENT :
POUR EVITER LES RISQUES D'INCENDIE OU D'ELECTROCUTION, NE PAS EXPOSER L'APPAREIL A L'HUMIDITE OU A LA PLUIE.

Ce magnéscope ne doit être utilisé que sur du courant direct en 7V.

ATTENTION :

Afin d'éviter tout resque d'incendie ou d'électrocution, ne pas utiliser d'autres sources d'alimentation électrique.

REMARQUE :

La plaque d'identification (numéro de série) se trouve sur le panneau arrière de l'appareil.

TENTATIVE



SAFETY PRECAUTIONS

WARNING:

TO REDUCE THE RISK OF FIRE OR ELECTRIC SHOCK, DO NOT EXPOSE THIS APPLIANCE TO RAIN OR MOISTURE.

This unit should be used with 7V DC only.

CAUTION:

To prevent electric shocks and fire hazards, do NOT use any other power source.

NOTE :

The rating plate (serial number plate) is on the body.

CAUTION

To prevent electric shock, do not open the cabinet. No user serviceable parts inside. Refer servicing to qualified service personnel.

AVERTISSEMENT :

POUR EVITER LES RISQUES D'INCENDIE OU D'ELECTROCUTION, NE PAS EXPOSER L'APPAREIL A L'HUMIDITE OU A LA PLUIE.

Ce magnéscope ne doit être utilisé que sur du courant direct en 7V.

ATTENTION :

Afin d'éviter tout resque d'incendie ou d'électrocution, ne pas utiliser d'autres sources d'alimentation électrique.

REMARQUE :

La plaque d'identification (numéro de série) se trouve sur le panneau arrière de l'appareil.

Thank you for purchasing the DV Camcorder GY-DV300.
These instructions are for the GY-DV300.

Mini DV

This camcorder is a MiniDV video system format camcorder.
Videocassettes that are not marked with the MiniDV symbol cannot be used with this unit.

- The following phenomena may occur when tapes recorded on other units (including another GY-DV300) are recorded or played back on this camcorder.
 - The transient section between scenes recorded on other units and those recorded on this unit may appear disturbed.
 - Digital noise may appear during playback due to tracking errors.
- In the case of important recordings, do not record within the first 2 to 3 minutes from the beginning of the tape.
- Before recording important scenes, be sure to perform a test recording and confirm that both video and audio are recorded correctly.
- We recommend using the "SP" mode for recording important scenes.
- Recorded video and audio contents are for private use. Other use may infringe on the rights of copyright holders.
- JVC cannot assume liabilities that may derive from the impossibility of normal recording or playback of video or audio due to malfunction of the camcorder or the videocassette.

About the LP Mode

Recording and playback quality in the LP mode is easily affected by the condition of the tape and the environment of use. Mosaic-like noise may appear in the playback picture and the sound may drop out at times, etc. The picture may also be disturbed at the transient sections between scenes.

MAIN FEATURES

- Newly developed built-in 12-bit DSP employed for high-quality picture
- High quality picture with 400% dynamic range
- Compact, lightweight design
- DV high-quality digital format
 - The 4:1:1 (U MODEL)/4:2:0 (E MODEL), 8-bit, 25 Mbps component digital signal processing of the format ensures recording and playback with high picture quality.
- High sound quality thanks to PCM audio
 - Two types of sampling, 16-bit, 48 kHz sampling and 12-bit, 32 kHz sampling, ensure high-quality digital audio.
- Camera section designed with 3-CCD system for high-quality picture
 - Three 1/3" CCDs with 380,000 (U MODEL)/440,000 (E MODEL) effective pixels employed. Digital processing for high quality picture reproduction.
- Super sensitivity F/11, 2000 lux
 - Enables shooting at normal indoor illumination eliminating the need for extra illumination.
- LOLUX for 2.65 lux (F1.6) illumination
 - Employment of LOLUX mode ensures +24 dB gain. This is ideal for difficult shooting conditions with almost no illumination.
- Zebra pattern video level indication on monitor screen
- Built-in color bar (SMPTE type)(U MODEL)/(EBU type)(E MODEL)
- Aspect ratio switchable between standard and wide-screen
 - Menu allows screen format setting to be switched between 4:3 format and LETTER BOX-screen (16:9).
- Time code reader/generator
 - Recording of SMPTE (U MODEL)/EBU(E MODEL)time code possible.
- Edit search function for convenient recording review
- Variable scan shutter
 - Eliminates flicker when shooting other screen pictures than NTSC (U MODEL)/PAL (E MODEL), such as computer monitor screens. Copes with the range from 60.6 Hz to 2084.6 Hz (U MODEL)/50.1 Hz to 2067.8 Hz (E MODEL).
- DV (i. LINK) connector
 - DV connector (4-pin) provided. Enables transfer of digital data to other equipment provided with DV connector.
- Built-in camera-shake compensation function
- Built-in 2.5" color LCD display
- Network connection possible (requires installation of the optional network pack KA-DV300)
 - This allows audio and video streaming data to be transmitted via LAN card or the data can be recorded on a memory card.

TENTATIVE

CONTENTS

INTRODUCTION		MANUAL ADJUSTMENTS	
Precautions for Proper Use	7	Manual Focus Adjustment	63
Routine and Periodical Maintenance	9	Using ND Filter	65
Precautions for Use of Head Cleaning Tape ...	10	Obtaining Natural Tint (White Balance)	66
Videocassette to be Used	10	Manual Iris Adjustment	68
Condensation	11	Manual Shutter Speed Adjustment	70
Characteristic CCD Phenomena	11	Manual Gain Adjustment	72
		Displaying Zebra Patterns for Adjustment	75
CONTROLS, INDICATORS AND CONNECTORS		Manual Adjustment of the Audio Recording Level	76
Right Side Section	12	Disabling Operation of the Camera-Shake Compensation Function	78
Rear Section	14	Adjusting the Quality of Camera Image	79
Left Side Section	18		
Front Section	20	PLAYBACK	
Top Section	21	Playback of Tape	80
Indications on LCD Screen and Viewfinder Screen	22	Blank Search	81
		Adjusting the Playback Sound Volume	82
PREPARATIONS		Outputting CH-3/CH-4 Channel Sound	83
Basic System	32		
Power Supply Preparation	33	EXTERNAL COMPONENTS	
AC Operation	33	Connecting a Video Component with DV Connector	84
Battery Pack Operation	34		
Attaching an External Microphone (optional) ..	36	MENU SCREEN	
		MENU Screen Structure	86
PREPARATIONS FOR OPERATION		Setting Menu Screens	88
Turning the Power ON	37	Contents of Menu Screens	90
Cassette Loading	38	TOP MENU Screen	90
LCD Screen Adjustment	39	SYSTEM Menu Screen	91
Adjustment of the Viewfinder	40	DISPLAY Menu Screen	94
Setting, Displaying and Recording the Date and Time	41	CAMERA Menu Screen	96
Charging the Built-in Battery	44	OPERATION Menu Screen	98
Setting, Displaying and Recording the Time Code	45	CLOCK/TC Menu Screen	99
		VTR Menu Screen	99
SETTINGS BEFORE SHOOTING		TROUBLESHOOTING	
Shooting Mode (AUTO/MANUAL) Selection ...	47	Alarm Indications and Actions	100
Audio Input Signal Selection	49	In case of Difficulty	102
Audio Monitor Selection	51		
Focus Mode Selection	52	OTHERS	
Angle of View (Zoom In/Zoom Out)	53	Displaying the Hour Meter Display	104
Menu Screen Settings	54	Specifications	105
SHOOTING			
Basic Recording Operation	57		
Viewing the Recorded Scene (Edit Search)	59		
If the Unit is Left in Recording-Standby Mode ..	60		
Recording the Color Bar	61		
Using the AE Function	62		

INTRODUCTION

Precautions for Proper Use

- Supply voltage
Make sure that the power is between 6 V and 12 V DC. If the power voltage is too low, abnormal colour and increased noise may occur. Do not exceed 12 V DC in any case, or the unit could be damaged.
- Allowable ambient temperature and humidity
Be sure to use the unit within the allowable temperature range of 0°C to 40°C and a relative humidity of 30% to 80%. Using the unit at a temperature or humidity outside the allowable ranges could result not only in malfunction but the impact on the CCD elements could be serious as small white spots may be generated. When storing the GY-DV300 for a long time, the storage temperatures should be -20°C to 60°C.
- Strong electromagnetic waves or magnetism
Noise may appear in the picture or audio and/or the colours may be incorrect if the camera is used near a radio or television transmitting antenna, in places where strong electromagnetic waves are generated by transformers, motors, etc., or near devices emitting radio waves, such as transceivers or cellular phones.
- If a transceiver or cellular telephone is used closed to the GY-DV300 while the camera-shake compensation function is in use, the camera image may flicker due to the influence of emitted electromagnetic waves.
- Use of wireless microphone near the camera
When a wireless microphone or wireless microphone tuner is used near the camera during recording, the tuner could pick up noise.
- Avoid using or placing the unit in places;
 - subject to extreme heat or cold;
 - with excessive dirt or dust;
 - with high humidity or moisture;
 - subject to smoke or vapour such as near a cooking stove;
 - subject to strong vibrations or on an unstable surface.
- also do not leave the unit for long hours in a parked car under direct sunlight or near room heating equipment.
- Protect the unit from being splashed with water (especially when shooting in the rain).
- Protect the unit from being wet when shooting on a beach.
In addition, salt and sand may adhere to the camera body. Be sure to clean the camera after use.
- Protect the unit against penetration of dust when using it in a place subject to sandy dust.
- Setup level (U MODEL)
The video signal of the unit's video output is not provided with a setup level when shipped from the factory. If you want to turn ON the setup level, please set the SET UP item on the SYSTEM menu screen to ON.
- Optical performance of lens
Due to the optical performance of the lens, color divergence phenomena (magnification chromatic aberration) may occur at the periphery of the image. This is not a camera malfunction.
- Use the unit in an upright position.
If placed on its side, heat release efficiency will deteriorate, adversely affecting the tape transport. Depending on the circumstances, the tape may also be damaged.
- Vibrations
Colours may fail to appear during VCR playback in locations subjected to vibrations.
- Precautions for transportation
Do not drop or hit the unit against a hard object.
- Remove the videocassette before transporting the unit.
- Do not insert other objects than a videocassette in the cassette insertion slot. Be sure to close the cassette cover when the unit is not to be used for a long period.

INTRODUCTION

Precautions for Proper Use (Cont'd)

- Do not set the POWER switch to OFF or remove the power cord during recording or playback. Otherwise the tape may be damaged.
- When the unit is not in use, be sure to set the POWER switch to OFF in order to reduce power consumption.
- Cleaning the camera body: Wipe the body with a dry, soft cloth. When it is extremely dirty, soak the cloth in a solution of neutral detergent, wring it out and then wipe. To prevent deformation of the body, etc. and to avoid operation hazards, do not allow volatile liquids such as benzene and thinner to contact the body, and do not wipe it with a cloth soaked in such a liquid.
- The camera may be unstable for a few seconds immediately after the power is turned on, but this is not a malfunction.

CAUTION

- Do not point the lens or viewfinder directly at the sun or other strong light source
 - Eye damage could result.
 - If the lens or viewfinder is left pointed at the sun, rays may collect inside the unit and cause damage or a fire.
- When carrying the camera, be sure to hold the carrying handle. Holding the LCD door, lens or viewfinder may result in damage.

Routine and Periodical Maintenance

The GY-DV300 incorporates precision mechanical parts, which will collect dirt, wear out and deteriorate as the unit is used. On the other hand, when the unit has been used for a long period in a normal environment, the heads, drums and tape transport mechanisms also accumulate dirt that is deposited on them. Furthermore, dust which penetrates the inside of the VCR section especially during outdoor use will promote the wear and deterioration of mechanical parts by causing poor contact between tape and heads or failure to maintain the video and audio quality at high levels. To prevent wear and deterioration, clean the mechanical parts using a head cleaning tape as routine maintenance. However, as cleaning with a head cleaning tape alone is not enough for cleaning the entire tape transport mechanism, it is also recommended to apply periodical maintenance (inspection) to prevent troubles that may be caused by the sudden occurrence of failure. As the replacement, adjustment and servicing of parts require advanced skill and equipment, please consult the person in charge of professional video equipment at your nearest JVC-authorized service agent.

Head Cleaning

- To maintain beautiful video and sound, be sure to use a head cleaning tape to clean the head periodically. (Read "Precautions for Use of Head Cleaning Tape" on page 10.) If head cleaning is not performed periodically, a type of mosaic noise called block noise may appear in the picture or sound may be interrupted.



Block Noise

- Use the optional head cleaning tape M-DV12CL. Do not use other than the designated head cleaning tapes. For instructions on how to use the head cleaning tape and precautions for its use, read "Precautions for Use of Head Cleaning Tape" on page 10.
- When dirt adheres to the video heads of the GY-DV300, the warning message "HEAD CLEANING REQUIRED!" appears on the LCD screen and the viewfinder screen during edit search in the recording mode and during playback.

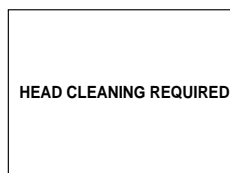

Periodical Maintenance

Contents: Check or replace the following mechanical parts according to the running time.

Running Time	500H	1000H	1500H	2000H
Drum assembly (including heads)	○	○	○	●
Head cleaner	☆	●	☆	●
Tape guides & rollers	○	☆	○	●
Rotary encoder	—	☆	—	●
Belts & gears	—	☆	—	●
Drive parts	○	☆	○	●

○: Clean, check and adjust.

☆: Clean and check. Replace as required.

●: Replace.

- The maintenance contents vary depending on the operating environment and method. Therefore, the above data should be considered as a reference.

Time management

The accumulated running time of the unit can be confirmed with the hour meter display (which shows the accumulated drum running time). For details, see "Displaying the Hour Meter Display" on page 104.

For consultations related to the maintenance programming or cost, please contact the person in charge of professional video equipment at your nearest JVC-authorized service agent.

TENTATIVE

INTRODUCTION

Precautions for Use of Head Cleaning Tape

Use the separately sold head cleaning tape M-DV12CL.

Adhere to the following precautions when using the head cleaning tape.

1. The tape runs for 10 seconds at a time in the PLAY mode. (The tape stops automatically and the unit enters the STOP MODE.)
 - Set the MODE switch on the unit to "VTR".
 - Press the BAR (▶/■) button after the cleaning tape is fully loaded.
 2. Do not use the tape more than four times at the most for each cleaning.
 3. The cleaning tape can be used approximately 100 times.
- Use the following chart as a guide for periodical head cleaning.

Operating environment	Low temperature 0°C to 10°C	Room temperature 10°C to 35°C	High temperature 35°C to 40°C
Yardstick for use of cleaning tape	1 to 2 times every 5 hours	1 to 2 times every 20 to 30 hours	1 to 2 times every 5 hours

- Note 1) When used in a low humidity environment (10% RH to 30% RH), head cleaning should be conducted at intervals half of those given in the above chart.
- Note 2) If an ME80 tape is used immediately after head cleaning, the VTR WARNING (HEAD) indicator may remain on. In this case, let the tape run as the indicator will turn off after the tape has run for a while.
- Note 3) Use the cleaning tape at room temperature (10°C to 35°C).
- Note 4) The cleaning tape case contains instructions for use of the cleaning tape. However, some of these instructions differ from the contents given in this document. When using the cleaning tape, please follow the instructions of this document.
- Note 5) Perform head cleaning before using the GY-DV300 in the LP mode.

Videocassette to be Used

- Use JVC videocassette tapes marked with MiniDV for this unit. Please use DVM60 or DVM30 type videocassettes.
- **Malfunctions may occur if a DVM80 videocassette is used in the LP mode.**
- When recording in the LP mode, use videocassettes bearing the "LP Mode" mark on the package. The following phenomena may occur when tapes recorded in the LP mode are attempted played back on another set.
 - Noise may appear in the picture and sound
 - The sound may fall out and the picture may fail to appear
 - The tape counter indication may be irregular
- Please play back a tape that is recorded in the LP mode on the unit on which the tape was recorded. Also, these tapes cannot be played back on digital video units that do not support the LP mode.
- Videocassettes cannot be used upside down.
- Avoid storing a videocassette with unevenly wound tape, as this may damage the tape. Rewind it to the beginning before placing a cassette into storage.
- Store videocassettes in a place with little humidity and good ventilation where mould does not form.
- After a videocassette tape has been used repeatedly, it becomes unable to maintain full performance due to an increase in noise caused by dropouts, etc. Do not continue to use a dirty or damaged tape, as this will reduce the rotary head life.
- Videocassette tapes marked MiniDV are provided with a switch on the back for use in preventing accidental erasure.
- Slide the switch to "SAVE" to protect the required recording in the tape from being overwritten.
- To record on the tape, slide the switch to "REC".

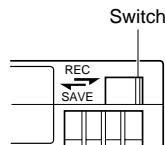

Condensation

- If the unit has been cooled down in a cold place and is then carried to a warm place, the moisture contained in the warm air may adhere to the head drum or tape guides and be cooled into water droplets. This phenomenon is referred to as condensation (dewing). When this occurs, the head drum and tape guides are covered with droplets allowing the tape to stick to them, leading to tape damage.
- Condensation occurs in the following cases:
 - When the unit is suddenly moved from a cold place to a warm place.
 - When a room heater has just started or when the unit is exposed directly to cold air from an air conditioner.
 - When the unit is placed in a very humid place.

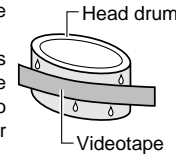

Do not leave the videocassette inserted when moving the camera under conditions where the temperature environment changes. After moving the unit, do not use until the internal parts have stabilized.

- When condensation occurs in this unit, the "VTR WARNING (DEW)" appears on the LCD screen and the viewfinder screen.

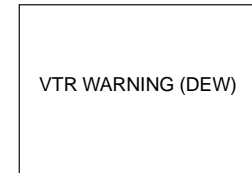

- To remedy, leave the unit with the power ON and wait until the WARNING indicator disappears.
- Prevention of condensation
When quickly transporting the GY-DV300 from a cold to a warmer place, first take out the cassette. Then place the GY-DV300 in a plastic bag and seal it before transporting the camera. Leave the GY-DV300 in the sealed plastic bag until the camera has the same temperature as the surroundings. This will prevent condensation.

Characteristic CCD Phenomena

Smear and Blooming

Due to the physical structure of a CCD it is possible to induce vertical streaking (called "smear") when shooting an extremely bright light source. Another effect is the expansion of light around a bright light or object (called "blooming"). The CCD employed in this unit is characterized by inducing very little smear or blooming. Nevertheless, please be careful when shooting a bright light source.

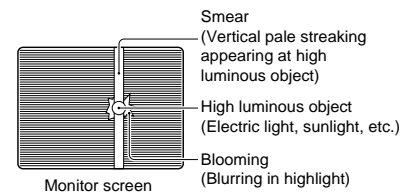

Moire or Aliasing

Shooting stripes or fine patterns may cause a jagged effect or a banding in fine mesh patterns.

White dots

High temperatures can cause CCD sensor pixels to malfunction with the effect of white dots in the image. This condition is conspicuous especially when gain is applied. This is a characteristic of the charged-couple device (CCD). As far as possible, use the unit under conditions where the temperature of the unit does not increase.

CONTROLS, INDICATORS AND CONNECTORS Right Side Section

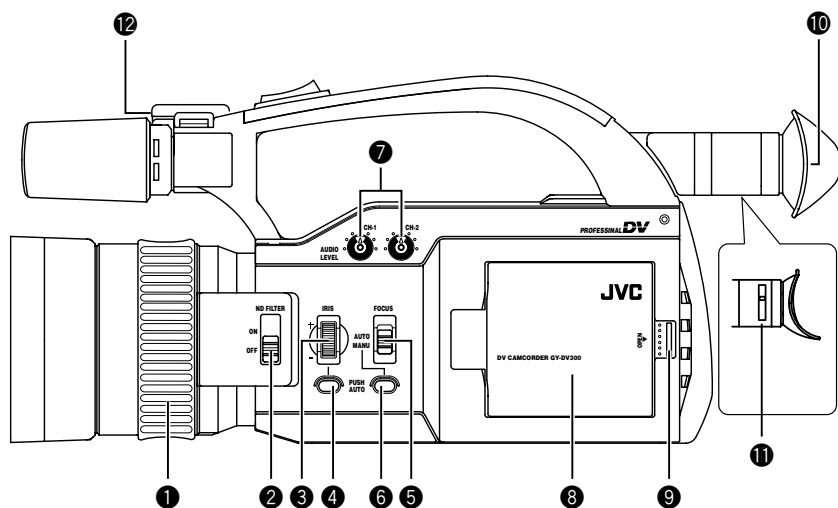

1 FOCUS ring

Manual focus ring.

Set the FOCUS switch 5 to "MANUAL" before turning this ring to adjust the focus manually. If the FOCUS switch is set to "AUTO", this ring will not work.

2 [ND. FILTER] ND-filter switch

Turns the built-in ND-filter ON or OFF. When the shooting conditions are too bright during outdoor shooting, set this switch to "ON". This will adjust the quantity of light to approximately 1/32. When this switch is ON, the "ND" indicator is shown on the LCD screen. (See page 24.)

3 [IRIS] IRIS adjustment dial

Dial for manual adjustment of iris. To allow iris adjustment with this dial, set the IRIS item to MANUAL on the OPERATION menu screen. When the MANUAL mode is selected for the iris adjustment, this dial can be rotated to move the iris from fully opened to fully closed. Rotating the dial upward opens the iris, and rotating it downward closes the iris.

When the AUTO mode is selected for the iris adjustment, this dial can be rotated to adjust the iris from +3 steps to -3 steps from the auto iris condition. Rotating the dial upward opens the iris, and rotating it downward closes the iris. (See "OPERATION Menu Screen" on page 98.)

4 [IRIS PUSH AUTO] Iris push auto button

Pressing this button when the MANUAL mode is selected for the iris adjustment engages the forced auto iris mode as long as the button is pressed. When the button is released, the manual mode is restored. When the AUTO mode is selected for the iris adjustment, this button does not work.

5 [FOCUS] Focus switch

This is used to switch between AUTO and MANUAL focus adjustment. Set this switch to "MANU" when the focus ring 1 should be used to adjust the focus.

6 [FOCUS PUSH AUTO] Focus push auto button

Pressing this button when the MANUAL mode is selected for the focus adjustment engages the forced auto focus mode as long as the button is pressed. When the button is released, the manual mode is restored. When the [FOCUS] switch 5 is set to "AUTO", this button does not work.

7 [CH1/CH2 AUDIO LEVEL] CH-1/CH-2 audio recording level controls

Used to adjust the recording level of the CH-1 and CH-2 audio channels. To use these controls to adjust the audio level, set the CH1 AUDIO LEVEL or CH2 AUDIO LEVEL item to MANUAL on the OPERATION menu screen. Rotating clockwise increases the recording level. The recording level meter is displayed on the LCD screen and the viewfinder screen.

8 LCD door

This is the door behind which the LCD screen is located. The LCD screen can be viewed when the door is open.

This door can be turned to face the LCD screen toward the lens (vertically inverted image) or downward. (See page 39.)

9 LCD door lock release button

Slide the button toward the rear side to open the LCD door.

10 Viewfinder

Displays the camera image and the playback picture.

The brightness and color saturation of the viewfinder screen can be adjusted on the DISPLAY [2/2] menu screen. The viewfinder can be turned approximately 75 degrees upward.

11 Viewfinder diopter adjustment knob

Knob for adjusting until the viewfinder screen image is clearly visible. Raise the viewfinder to facilitate the adjustment.

12 Tally lamp

This lamp lights up red when the GY-DV300 is in the recording mode. It blinks slowly when the battery pack is exhausted and when there is about 3 minutes or less tape remaining. When the tape has run out, or the VTR enters the warning mode, it blinks quickly. Use the TALLY item on the SYSTEM [2/2] menu screen to select whether or not the lamp should light during recording. (See page 92.)

TENTATIVE

CONTROLS, INDICATORS AND CONNECTORS **Rear Section**

TENTATIVE

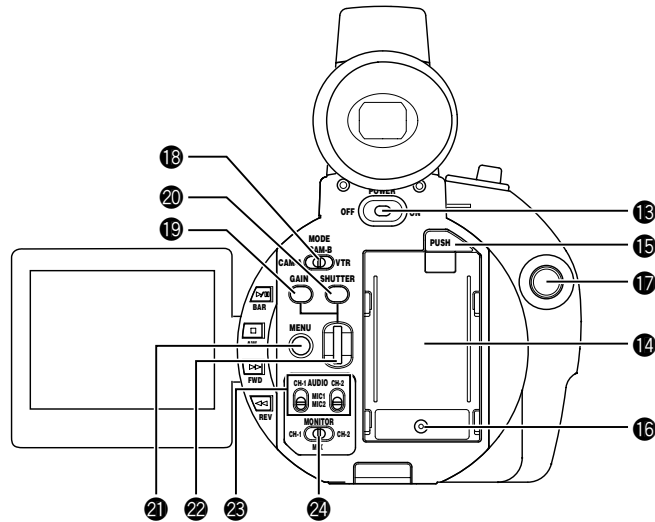

13 [POWER] POWER switch
Turn the power ON and OFF with this switch.

14 Battery holder (U MODEL)
Mount the provided battery pack BN-V428 here. (See page 34.)

14 Battery holder (E MODEL)
Mount the optional battery pack BN-V416 or BN-V428 here. (See page 34.)
The BN-V416 battery pack cannot be used when the optional Network Pack KA-DV300 is used.

15 Battery lock release button
Press this button to remove the battery pack.

16 [DC INPUT] DC connector
Power input connector for 7 V DC. Accepts the optional AC adapter AA-P30. The power range is 6 V to 12 V.

17 REC Start/Stop button
This button starts and stops recording. When the GY-DV300 is in the shooting mode, pressing this button starts the recording. Pressing the

button during a recording engages the recording-pause (standby) mode.

18 [MODE] Mode selector switch
Set in accordance with the operating mode of the GY-DV300. When used in the shooting mode, the switch is set to "CAM-A" or "CAM-B". When used in the VTR playback mode, it is set to "VTR". When set to "CAM-A" or "CAM-B" in the shooting mode, two separate sets of setting values for recording can be set by means of the menu screens.

"CAM-A" : In this position, shooting takes place in accordance with the conditions set for "CAM-A" on the menu screen.

"CAM-B" : In this position, shooting takes place in accordance with the conditions set for "CAM-B" on the menu screen.

"VTR" : Set to this position when performing VTR playback.
Also set to this position to record the video signal input from the DV

connector.

19 [GAIN] Sensitivity selector button
This button is for manual adjustment of sensitivity. It works when the AE item is set to OFF on the OPERATION menu screen.

- When the AE (Auto Exposure) function is OFF and this button is pressed, the condition of the current gain setting is shown on the LCD screen or the viewfinder screen for about 3 seconds. In this condition, it is possible to set the gain setting of the GY-DV300. Gain is set by rotating the SELECT dial 22. Rotating the dial upward moves gain in the plus direction, and rotating it downward moves it in the minus direction.

When rotation of the dial stops, the set gain is indicated for about 3 seconds.

[The variable range is -3 dB to +18 dB (1 dB step)]

- Pressing the button for 1 second or more engages the LOLUX mode.

20 [SHUTTER] Shutter speed selector button
This button is for manual adjustment of the shutter speed.

- It works when the AE item on the OPERATION menu screen is set to OFF. Using the SHUTTER item on the OPERATION menu screen, select the shutter speed mode as STEP or VARIABLE.

Set to VARIABLE when shooting computer display screens.

- When the button is pressed in MANUAL mode, the current shutter speed setting is shown on the LCD screen or the viewfinder screen for about 3 seconds. In this condition, it is possible to set the shutter speed of the GY-DV300. The shutter speed is set by rotating the SELECT dial 22. When rotation of the dial stops, the set shutter speed is indicated for about 3 seconds.

[Variable range (U MODEL)

STEP: 1/60, 1/100, 1/250, 1/500, 1/1000, 1/2000

VARIABLE: 1/60.1 to 1/2084.6]

[Variable range (E MODEL)

STEP: 1/50, 1/120, 1/250, 1/500, 1/1000, 1/2000

VARIABLE: 1/50.1 to 1/2067.8]

21 [MENU] Menu button

Press this button for 1 second or more to display the MENU setting screen. The MENU setting screen is shown on the LCD screen and the viewfinder screen.

When the OUTPUT CHAR. item on the DISPLAY [2/2] menu screen is set to MIX, the MENU setting screen can also be output for display via the VIDEO OUT or Y/C OUT connector.

Selections and settings in the menu are performed with the SELECT dial 22.

The normal screen returns when this button is pressed while the MENU setting screen is displayed.

22 SELECT dial

- When gain and shutter adjustment is set to the MANUAL mode, this dial is rotated to set the gain or shutter speed.

- When the white balance adjustment is set to the MANUAL mode, the white balance setting mode can be selected by rotating this dial.

[Variable range: PRESET, MEMORY 1, 2, 3]

- When the MENU setting screen is displayed, this dial is used to select and set items in the menu.

To confirm menu items and set values, press the dial.

23 [CH-1/CH-2 AUDIO] CH-1/CH-2 audio input selector switch

Used to select the audio source input to the CH-1/CH-2 channel. Separate inputs can be selected for the CH-1/CH-2 channels.

MIC 1 : The sound from the built-in microphone or from the MIC 1 input connector is input. Select the input from the built-in microphone or from the MIC 1 input connector with the MIC1 INPUT SEL item on the SYSTEM [1/2] menu screen.

MIC 2 : The sound from the MIC 2 input connector is input.

24 [MONITOR] Audio monitor selector switch

Selects the monitor sound heard from the EARPHONE jack 24 or the built-in speaker.

CH-1 : CH-1 audio signal

CH-2 : CH-2 audio signal

MIX : Mixed signal consisting of the CH-1 and CH-2 audio signals.

CONTROLS, INDICATORS AND CONNECTORS Rear Section (cont'd)

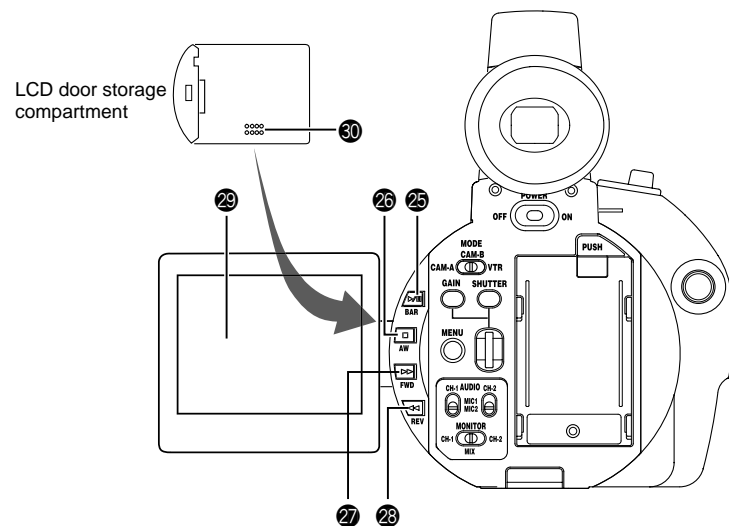

25 [BAR] Color bar/Playback & still button

- Pressing this button in the shooting mode switches the setting between color bar output and camera image output.
- Pressing this button in the VTR playback mode starts playback. Pressing this button during playback engages the playback mode.
- Pressing this button during playback engages the still picture mode.

26 [AW] White balance/Stop button

- Used when white balance adjustment is performed in the shooting mode. To use this button for white balance adjustment, the WHITE BALANCE item on the OPERATION menu screen should be set to PUSH AUTO. When this button is pressed, the current white balance setting mode is displayed for about 3 seconds on the LCD screen or the viewfinder screen after which white balance adjustment of the GY-DV300 becomes possible. The white balance adjustment setting mode is selected by rotating the SELECT dial 22. When rotation of the dial stops, the selected

setting mode is displayed for about 3 seconds. When the button is then pressed for 1 second or more, the white balance adjustment starts. [Variable range: PRESET, MEMORY 1, 2, 3]

Memo:

The PRESET mode is fixed at 3200 K (colour temperature). Even if the AW button is pressed, white balance adjustment is not performed.

- Pressing this button in the VTR playback mode engages the Stop mode.

27 [FWD] FORWARD/FF button

- Pressing this button in the shooting mode engages playback in forward direction at normal speed for as long as the button is pressed. When the button is released, the recording-standby mode is engaged.
- Pressing this button in the VTR playback mode during stop or rewind operation initiates the fast forward mode. Pressing this button during playback, still picture playback, or reverse search initiates forward search mode.

- Pressing this button simultaneously with the REV button 28 during stop in the VTR playback mode initiates the blank search mode (for locating the end point of recordings).

28 [REV] REVERSE/REW button

- Pressing this button in the shooting mode engages playback in reverse direction at normal speed for as long as the button is pressed. When the button is released, the recording-standby mode is engaged.
- Pressing this button in the VTR playback mode during stop or fast forward operation initiates the rewind mode. Pressing this button during playback, still picture playback, or forward search initiates reverse search.

29 LCD monitor screen

- Shows a color camera image or the VTR playback picture. It is also used for displaying the following:
 - Menu setting screens
 - Characters showing the whether the GY-DV300 is set to shooting mode or VTR playback mode
 - Date and time and time code
 - Audio level meter
 - Warning indications, etc. For details, see page 22.
- The angle of the LCD screen can be rotated to make the LCD screen face toward the lens or downward.
- The brightness and color saturation can be adjusted and set on the DISPLAY [1/2] menu screen.

30 Built-in speaker

- Outputs the VTR playback sound. The playback sound level is adjusted with the ZOOM/Playback sound level adjustment lever 41. The monitor sound is not output in the shooting mode. The audio from the loudspeaker is not output when an earphone is plugged into the EARPHONE jack 31. (See page 82.)

TENTATIVE

CONTROLS, INDICATORS AND CONNECTORS Left Side Section

TENTATIVE

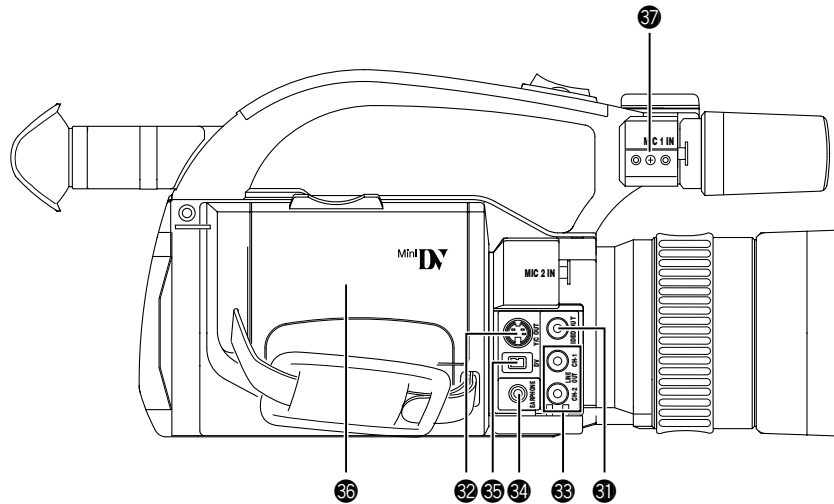

31 [VIDEO OUT] Video output connector (RCA)

Output connector for composite video signal. Outputs the input video signal and playback picture.

- When the OUTPUT CHAR. item on the DISPLAY [2/2] menu screen is set to MIX, on-screen-indicators like those shown on the LCD monitor screen can be output (black and white display).
- When the SETUP item on the SYSTEM [2/2] menu screen is set to ON, signals with setup information can be output. (black and white display) (U MODEL)

32 [Y/C OUT] Y/C video output connector (4-pin)

Separate YC video signal output connector. Outputs the input video signal and playback picture.

- When the OUTPUT CHAR. item on the DISPLAY [2/2] menu screen is set to MIX, on-screen-indicators like those shown on the LCD monitor screen can be output (black and white display).

- When the SETUP item on the SYSTEM [2/2] menu screen is set to ON, signals with setup information can be output. (black and white display) (U MODEL)

- When the ASPECT item is set to LETTER on the SYSTEM [2/2] menu screen, an ID signal for identifying the wide-screen aspect is output.

33 [CH-1/CH-2 LINE OUT] CH-1/CH-2 audio output connector (RCA)

Output connector for audio signal. In the shooting mode the input audio signal is output. In the VTR mode the playback sound is output.

34 [EARPHONE] Earphone jack

This is a jack for connecting an earphone for monitoring the sound. Plug in an earphone or headphone with a 3.5 mm diameter plug. Monaural sound is output. Select the output sound with the MONITOR switch 24. The volume of the monitor sound in the shooting mode is set with the EARPHONE LEVEL item on the TOP MENU screen.

The playback sound from the built-in speaker is not output when an earphone is plugged into this jack.

35 [DV] DV connector (U MODEL)

Using a DV cable (optional), a digital video component with DV connector can be connected here.

To record DV signals (IEEE1394 signals) from this connector, the MODE switch 18 should be set to "VTR".

36 [DV] DV connector (E MODEL)

Using a DV cable (optional), a digital video component with DV connector can be connected here.

This connector is used for output of the DV signal or input the VCR control signal from the digital video component with DV connector.

The use this connector, set the MODE switch 18 to "VTR".

Memo:

The GY-DV300 is not capable of recording DV signals (IEEE1394 signals).

36 Cassette cover

Sliding the EJECT switch located on the top section opens this cover to allow insertion or removal of the videocassette. The cover locks into place when it is closed after the cassette holder has been properly locked. (See page 38.)

Memo:

- When inserting a cassette, push the "PUSH HERE" section on the cassette holder to lock the cassette holder correctly, and then close the cassette cover.
- To prevent foreign matter from penetrating into the interior of the GY-DV300, never leave the unit with this cover left open.
- The GY-DV300 does not function if the cassette cover is not closed.

37 Microphone holder attachment base

Use for attaching an optional microphone holder. Attach the optional microphone holder KA-A33 here. (See page 36.)

CONTROLS, INDICATORS AND CONNECTORS **Front Section**

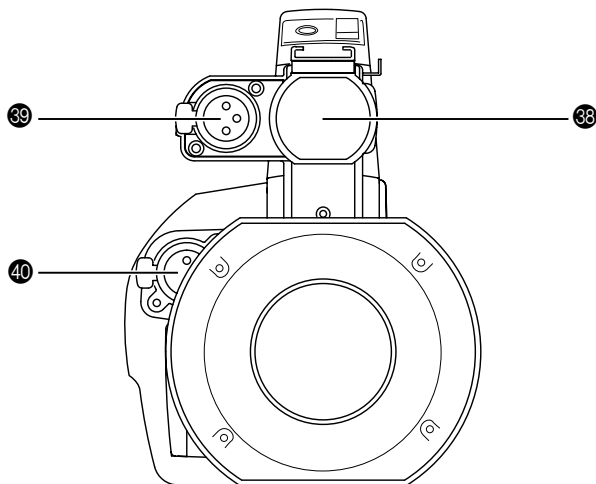

38 Built-in microphone

Built-in monaural microphone.

- To use this microphone, set the MIC1 INPUT SEL item to INT on the SYSTEM [1/2] menu screen.

39 [MIC 1] Microphone 1 input connector (XLR-3P)

Connect an external microphone to this connector. Monaural signals are recorded.

- To use the microphone connected to this connector, set the MIC1 INPUT SEL item to XLR on the SYSTEM [1/2] menu screen.
- To use a microphone requiring +48 V power supply (phantom microphone), set the +48V MIC1 item on the SYSTEM [1/2] menu screen to ON. This connector will then supply +48 V DC current.

When using a microphone other than a phantom microphone, set the +48V MIC1 item to OFF.

40 [MIC 2] Microphone 2 input connector (XLR-3P)

Connect an external microphone to this connector. Monaural signals are recorded.

- To use a microphone requiring +48 V power supply (phantom microphone), set the +48V MIC2 item on the SYSTEM [1/2] menu screen to ON. This connector will then supply +48 V DC current. When using a microphone other than a phantom microphone, set the +48V MIC2 item to OFF.

Memo:

- The audio input channel is selected with the CH-1/CH-2 audio input selector switch 20.
- To reduce the wind noise of the microphone, set the WIND CUT MIC1/MIC2 item on the SYSTEM [1/2] menu screen to ON.

TENTATIVE

CONTROLS, INDICATORS AND CONNECTORS **Top Section**

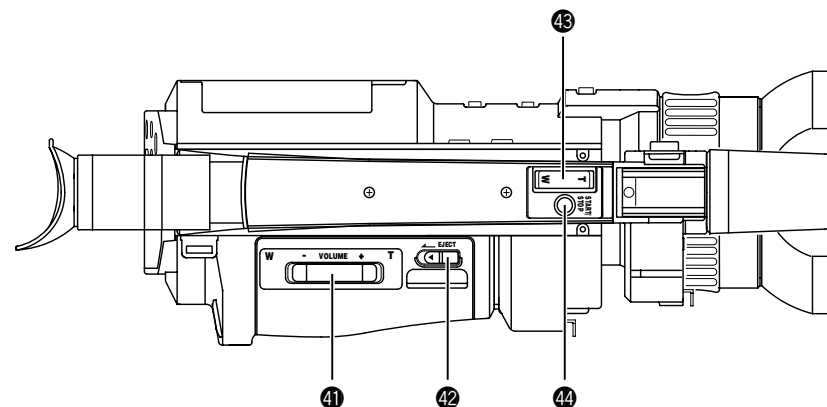

41 ZOOM/Playback sound level adjustment lever

- This works as the zoom lever in the shooting mode. Pressing the lever in the T direction narrows the lens angle perspective for telephoto shots. Pressing it in the W direction increases the angle of the lens for a wider shooting angle. The harder the lever is pressed, the quicker the zoom action.
- In the VTR playback mode, this lever is used for adjusting the playback sound level. Pressing the lever in the + direction increases the volume level, and pressing in the - direction decreases the level.

42 [EJECT] Eject switch

Slide to the side when inserting or ejecting the videocassette. Sliding this button and then opening the cassette cover will eject the cassette.

43 [ZOOM] Zoom lever

Lever for zoom operation from the handle top section.

- In the shooting mode, pressing this lever in the T direction narrows the lens angle perspective for telephoto shots. Pressing it in the W direction increases the angle of the lens for a wider shooting angle. The zoom speed of this zoom lever is selected with the HANDLE ZOOM item on the SYSTEM [2/2] menu screen.

44 [START/STOP] REC START/STOP button

Button for start and stop of recording from the handle top section.

When the GY-DV300 is in the shooting mode, pressing this button starts the recording. Pressing the button during a recording engages the recording-standby mode.

CONTROLS, INDICATORS AND CONNECTORS

Indications on LCD Screen and Viewfinder Screen

TENTATIVE

In addition to the E-E picture and the playback picture, the following indications are displayed on the LCD screen and the viewfinder screen.

- Status screens (screens for use in checking the current camera settings)
- Event indications
- Alarm indications
- Menu setting screens
- Auto white balance operation indicator

When the LCD screen is used, the above indicators are not shown on the viewfinder screen.

When the LCD screen is faced toward the viewfinder screen side and the LCD door is closed, the above indicators appear on the viewfinder screen.

■ Status Screens

The contents of the status screens differ in the camera shooting mode and in the VTR playback mode. Also, the items displayed on the status screen differ with the direction that the LCD screen is facing, i.e., toward the viewfinder (normal display) or toward the lens (vertically inverted display).

Normal display in the shooting mode

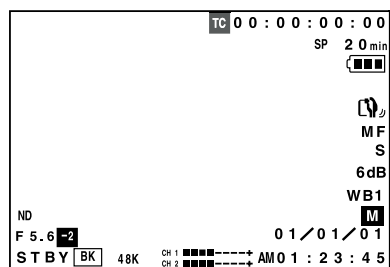

Vertically inverted display in the shooting mode

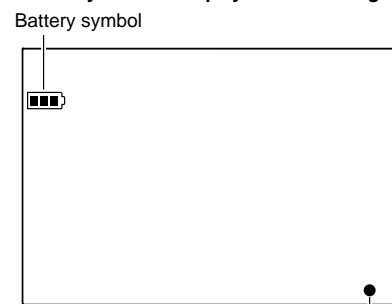

VTR operation symbol (Recording or pause)

For a part of the status indicators it is possible to select whether or not the item should be displayed by making a selection on the DISPLAY [2/2] menu screen.

In relation to the normal display, the vertically inverted display is reversed left to right, and only the battery symbol and the recording symbol/pause symbol are displayed.

- When the LCD screen is faced toward the lens side and the LCD door is closed, the normal display will be seen.

Memo:

After-images will increase on the LCD screen when used under cold circumstances.

Normal display in the shooting mode

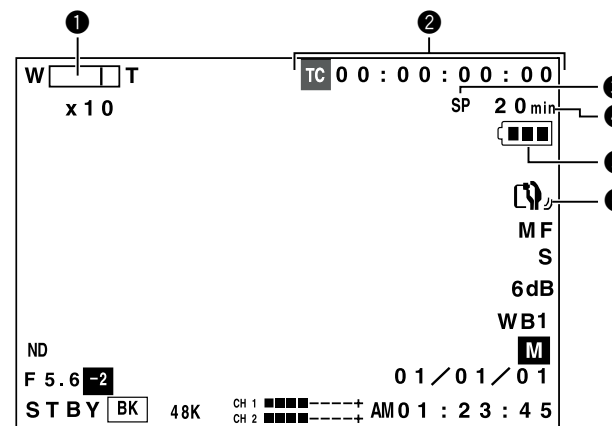

No.	Item	Contents
①	Zoom ratio (Characters, numeric value)	Displayed during zoom operation. The characters indicate the wide-angle (W) and telephoto (T) zoom positions. The numeric value indicates the approximate zoom ratio.
②	Time code display	Shows the time code (hours, minutes, seconds, frames). Whether this should be displayed can be selected by setting the TIME CODE item on the DISPLAY [2/2] menu screen.
③	Recording time mode indication	Shows the recording speed at the time of the recording. SP : Standard Play mode LP : Long Play mode When the remaining tape indication is OFF, this indication is shown at the ④ position.
④	Remaining tape time indication	Indicates the remaining tape amount (minutes) in 1-minute steps. Whether this indication should be ON or OFF can be selected by setting the TAPE REMAIN item on the DISPLAY [2/2] menu screen. * The indication may not appear when a new tape is loaded, after the tape runs, the indication appears.
⑤	Remaining battery power indication	The remaining battery power is indicated by four different indicators.  Fully charged battery Blinking indicator (no remaining battery power)
⑥	Camera-shake compensation on indication	Displayed when the camera-shake compensation function is on (OIS item on the OPERATION menu screen is set to ON).

CONTROLS, INDICATORS AND CONNECTORS Viewfinder Screen (Cont'd)

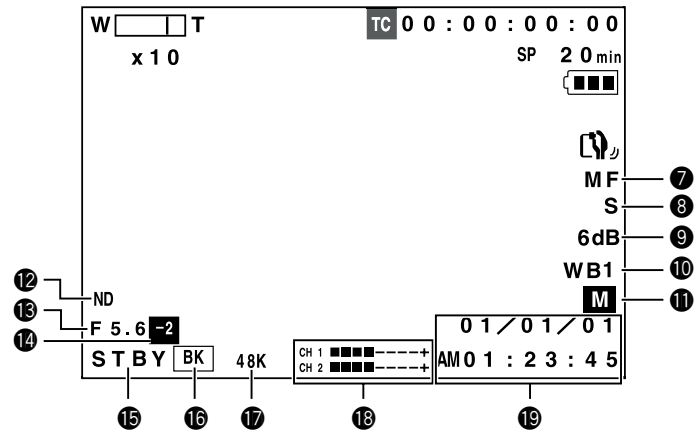

No.	Item	Contents
7	Manual focus indication	MF: Displayed when manual focusing is enabled (when the FOCUS switch is set to MANUAL).
8	Manual shutter mode indication	S: Displayed in the manual shutter mode (when the AE item is set to OFF on the OPERATION menu screen). This indication is not shown when the shooting mode is AUTO or the AE item is set to ON. It is not shown when the shutter is NORMAL (1/60 (U MODEL)/1/50 (E MODEL)) or gain is set to ALC.
9	Manual gain mode indication	Indicated in the manual gain setting mode (when the AE item is set to OFF on the OPERATION menu screen). 6 dB: The gain value is indicated for anything but 0 dB, LOLUX, or ALC. L: Displayed in LOLUX mode. The indication is not shown when the gain setting is 0 dB or ALC. It is not shown when the shooting mode is AUTO, or the AE item is set to ON.
10	Manual white balance mode indication	Displayed when manual white balance adjustment is enabled (when the WHITE BALANCE item is set to PUSH AUTO on the OPERATION menu screen). Indicates the white balance setting mode. WBP: White Balance Preset mode (fixed at a colour temperature of 3200 K. Manual white balance adjustment is inhibited.) WB1: White Balance memory 1 mode WB2: White Balance memory 2 mode WB3: White Balance memory 3 mode When WB1, WB2 or WB3 is indicated, manual white balance adjustment is enabled. The result of the white balance adjustment is retained in the indicated memory. It is not shown when the shooting mode is AUTO, or when the WHITE BALANCE item is set to AUTO.

TENTATIVE

No.	Item	Contents
11	Shooting mode indication	Indicates whether the shooting mode is AUTO or MANUAL. A: Displayed when the shooting mode is AUTO (when the MODE item is set to AUTO on the TOP MENU screen). M: Displayed when the shooting mode is MANUAL (when the MODE item is set to MANUAL on the TOP MENU screen).
12	Filter indication	ND: Displayed when the ND filter switch is set to ON.
13	Iris F-value indication	Indicates the F-value of the lens in the manual iris adjustment mode (when the IRIS item is set to MANUAL on the OPERATION menu screen). The indications are: F1.6, F2, F2.8, F4, F5.6, F8, F11, F16. CLOSE
14	Iris compensation value indication	-3 ~ ±0 ~ +3: Indicates the compensation value set with the iris adjustment dial in the auto iris mode. M: Displayed in the manual iris adjustment mode.
15	VTR mode indicators	STBY: Recording-standby mode REC: During recording ED.FWD: During playback in forward direction ED.REV: During playback in reverse direction STOP: Tape protect mode EJECT: During cassette ejection ---: Tape is not loaded
16	Fade indication	Displayed when the fade function is ON (when the FADER item is set to BLACK on the SYSTEM [2/2] menu screen). BK: Displayed when the FADER item is set to BLACK. (Fade-in and fade-out from black screen.)
17	Audio sampling frequency indication	32K: Displayed when the AUDIO MODE item is set to 32K on the SYSTEM [1/2] menu screen. (Audio is recorded with 12-bit, 32 kHz sampling.) 48K: Displayed when the AUDIO MODE item is set to 48K on the SYSTEM [1/2] menu screen. (Audio is recorded with 16-bit, 48 kHz sampling.)
18	Audio level meter display	Indicates the audio levels of CH-1, CH-2. These meters are not shown when the AUDIO LEVEL item is set to OFF on the DISPLAY [2/2] menu screen.
19	Date and time indication	Shows the date and time. The indication is enabled/disabled by selecting the TIME/DATE item on the DISPLAY [2/2] menu screen. The display style is selected by setting the DISP STYLE item. When the date and time are not set, the indication will be as follows. -- / -- / -- -- : -- : --

CONTROLS, INDICATORS AND CONNECTORS

Indications on LCD Screen and Viewfinder Screen (Cont'd)

Vertically inverted display indications in the shooting mode

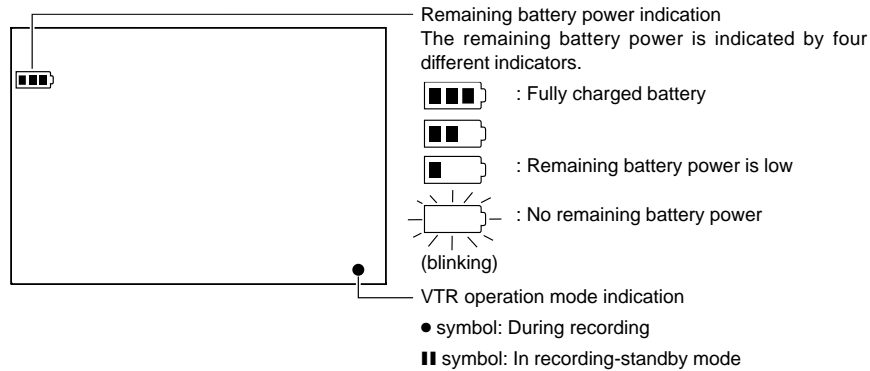

TENTATIVE

VTR playback mode/IEEE1394 recording mode status indications

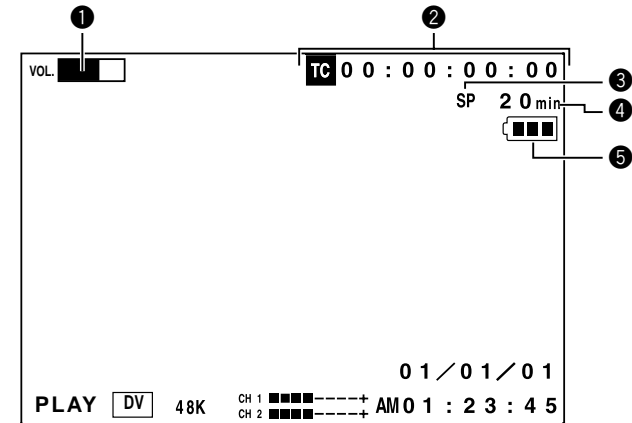

No.	Item	Contents
①	Audio playback volume indication	Displayed in the VTR mode. Characters indicate the high and low of the playback volume.
②	Time code indication	The recorded time code data (hours, minutes, seconds, frames) are shown here in the playback mode. The indication is turned ON/OFF by setting the TIME CODE item on the DISPLAY [2/2] menu screen.
③	Recording/playback speed mode indication	The mode in which the tape was recorded is displayed during playback. SP: Standard Play mode LP: Long Play mode When the remaining tape time indication is set to OFF, this indication is shown at the position indicated by ④.
④	Remaining tape time indication	Indicates the remaining tape time in 1-minute steps. The indication is turned ON/OFF by setting the TAPE REMAIN item on the DISPLAY [2/2] menu screen. * The indication may not appear when a new tape is loaded, after the tape runs, the indication appears.
⑤	Remaining battery power indication	The remaining battery power is indicated by four different indicators. Fully charged battery Blinking indicator (no remaining battery power)

CONTROLS, INDICATORS AND CONNECTORS **Indications on LCD Screen and Viewfinder Screen (Cont'd)**

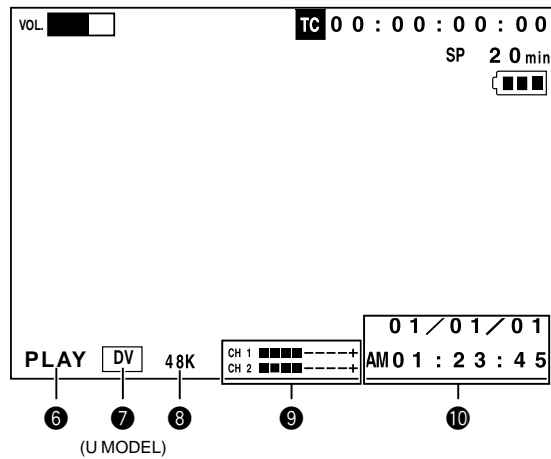

No.	Item	Contents
6	VTR mode indication	Indicates status of VTR operation. (STOP, PLAY, FF, REW, EJECT, STBY, FWD, REV, BSRH)
7	DV signal indication (U MODEL)	[DV]: Displayed when IEEE1394 signal is recorded from the DV connector.
8	Audio sampling frequency indication	The audio sampling frequency by which the recording was made is displayed during playback. (32K, 48K, 44.1K)
9	Audio level meters display	The playback audio level meters are displayed during playback. These are not shown when the AUDIO LEVEL item is set to OFF on the DISPLAY [2/2] menu screen.
10	Date and time indication	Recorded data is show during playback, fast forward and rewind operations. During recording, the data from the DV connector is shown. The current data is shown in the stop mode. The indication is enabled/disabled by selecting the TIME/DATE item on the DISPLAY [2/2] menu screen. The display style is selected by setting the DISP STYLE item. When the date and time are not set, the indication will be as follows. --/ --/ -- --: -: --

Event Indications

When the gain and shutter speed are changed manually, the set condition is displayed for about 3 seconds at the time the change is made.

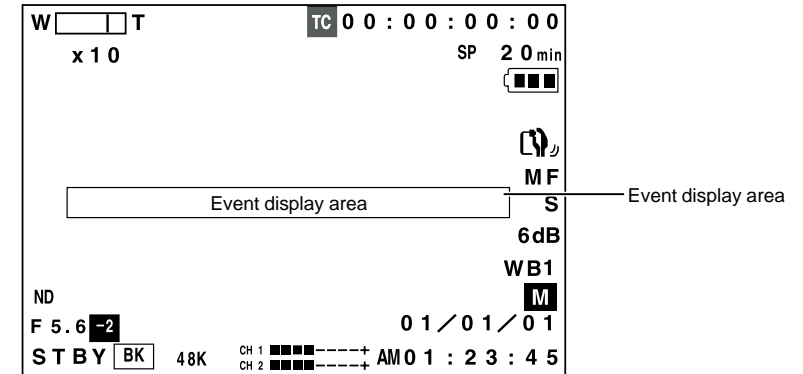

Set Condition	Contents of Indication
When the gain value is changed	GAIN -3 dB to 18 dB (1 step)
When the LOLUX gain mode is selected	LOLUX
When the shutter speed is changed	SHUTTER 1/100, 1/250, 1/500, 1/1000, 1/2000 (U MODEL) 1/120, 1/250, 1/500, 1/1000, 1/2000 (E MODEL)
When the variable shutter speed is changed	V.SHUTTER 1/60.1 - 1/2084.6 (U MODEL) 1/50.1 - 1/2067.8 (E MODEL)
When the shutter is NORMAL (shutter speed: 1/60)	SHUTTER NORMAL

TENTATIVE

CONTROLS, INDICATORS AND CONNECTORS

Indications on LCD Screen and Viewfinder Screen (Cont'd)

TENTATIVE

■ Alarm indications

Alarm indications are displayed under the following circumstances. The warning messages are shown blinking.

- When remaining battery power or remaining tape is low.
- Improper operation attempted.
- Abnormality generated in the GY-DV300.

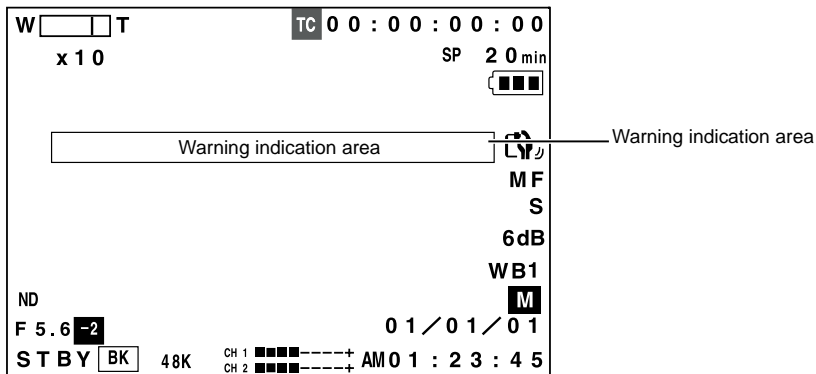

Warning Indication	Contents
TAPE NEAR END	Displayed when the remaining tape is 3 minutes or less in the shooting mode. It is not shown in the playback mode.
TAPE END	Displayed when the tape has run out.
TAPE BEGIN	Displayed when the tape is at the beginning position.
LOW VOLTAGE	Displayed when remaining battery power becomes low.
CLOSE CASSETTE COVER!	Displayed when operation is attempted while the cassette cover is open.
NO TAPE	Displayed when no videocassette is inserted and the VTR trigger button is pressed.
REC INHIBIT	Displayed when an unrecordable videocassette (the switch on the back of the cassette is set to "SAVE") is loaded.
1394 INHIBIT (U MODEL)	Displayed if an attempt to record is made when no DV signal is input.
COPY INHIBIT	Displayed when attempt to record a copy-guard protected signal is made.
CASSETTE COVER OPEND!	Displayed when the cassette cover was opened during recording.
CASS.CARRIAGE UNLOCK	Displayed when the cassette cover is closed but the cassette holder is not locked.
VTR WARNING [DEW]	Displayed when condensation occurs in the unit.
HEAD CLEANING REQUIRED!	Displayed in case of video head clogging.
VTR WARNING (HARD)	Lights when abnormality occurs in the unit.
VTR WARNING (TAPE)	Displayed when the tape is cut.

■ MENU Setting Screen

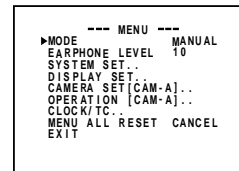

Used for making a variety of settings. See "MENU Setting Screen" on page 86.

■ Auto White Balance Indication

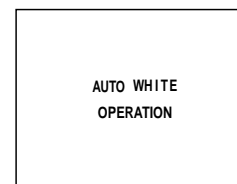

AUTO WHITE and the result of the operation are displayed when the auto white balance adjustment is performed. See "Auto White Balance Adjustment" on page 66.

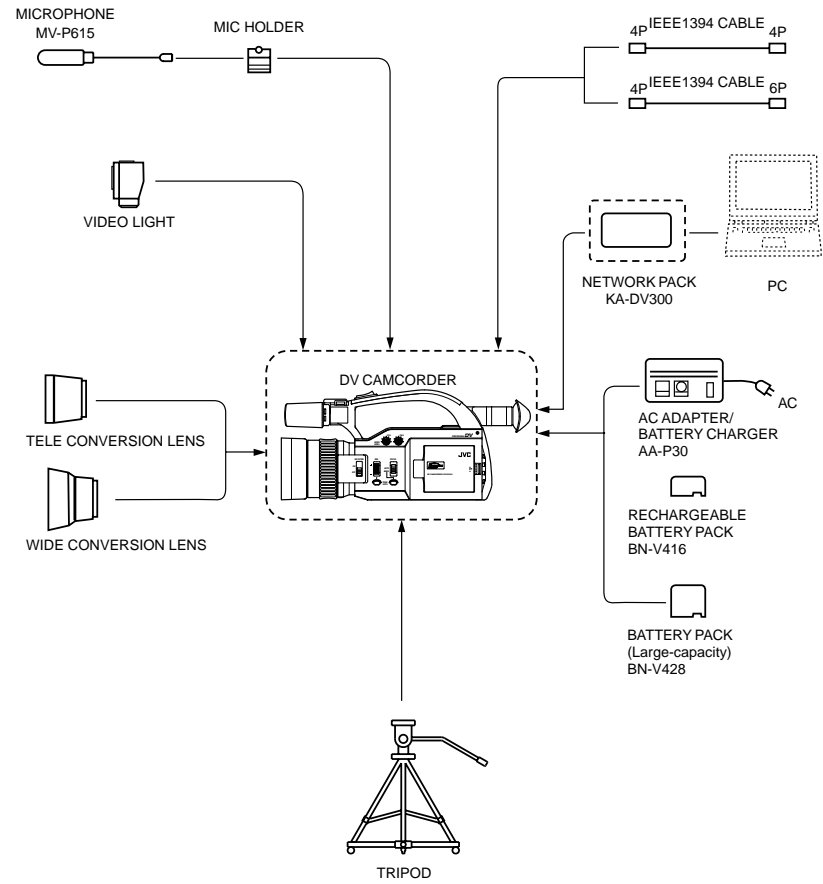
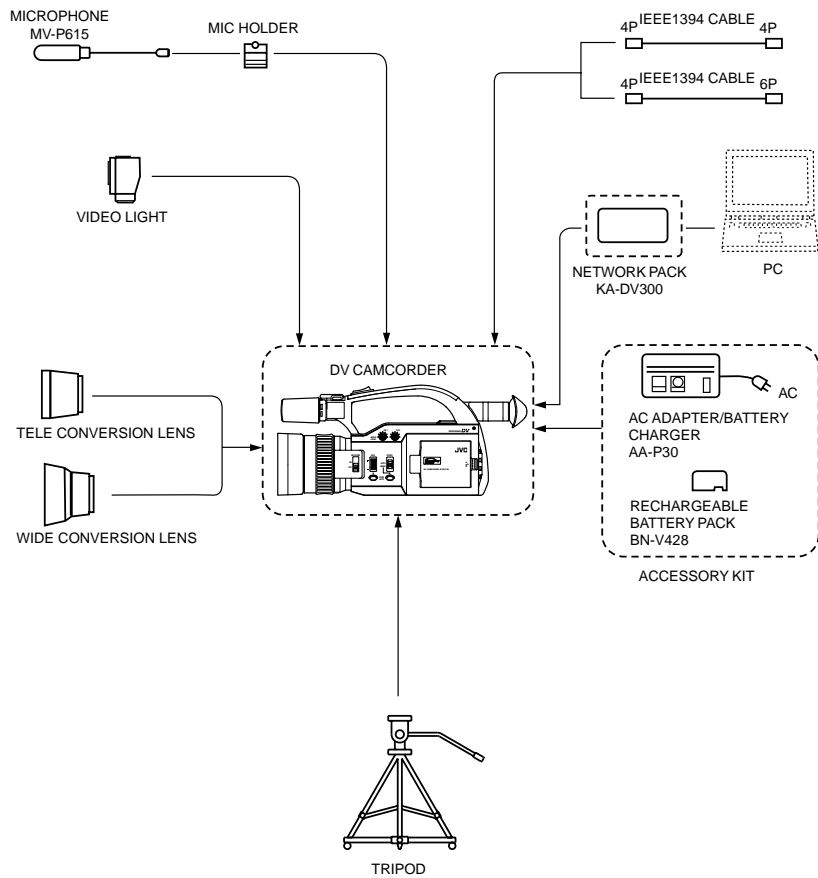

TENTATIVE

PREPARATIONS Power Supply Preparation

The GY-DV300 is operable with AC power supply or battery pack.

AC Operation

Use the provided (U MODEL)/optional (E MODEL) AC Adapter/Charger AA-P30 as the AC power supply. The DC INPUT connector on the GY-DV300 accepts power voltage in the range of DC 6V to DC 12V.

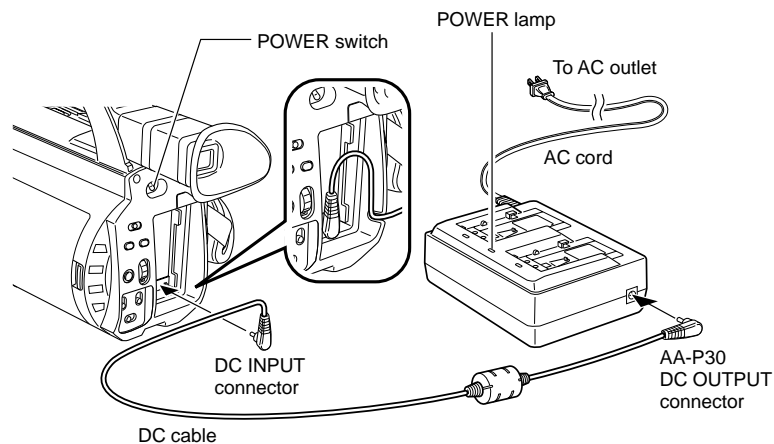

- Set the POWER switch on the GY-DV300 to OFF.
If a battery pack is attached to the unit, detach the battery pack.

1. Plug one end of the DC cable provided with the AC Adapter/Charger into the DC INPUT connector of the GY-DV300, and then connect the other end to the DC OUTPUT connector on the AC Adapter/Charger.
2. Plug the AC cable of the AC Adapter/Charger into an AC outlet. The POWER lamp illuminates when power is supplied to the AC Adapter/Charger.

* For details, see the instruction manual for the AA-P30.

CAUTION:

- Do not disconnect or connect the DC cable or AC cord while recording is taking place.
 - Remaining battery power indication when the AC adapter is used
- When the optional Network Pack KA-DV300 is connected, the remaining battery power indication for fully charged battery may not be displayed.



Fully charged

TENTATIVE

PREPARATIONS Power Supply Preparation (cont'd)

Battery Pack Operation

Use the provided battery pack BN-V428 for battery pack operation. (U MODEL)
Use the optional battery pack BN-V416 or BN-V428 for battery pack operation. (E MODEL)
The BN-V416 battery pack cannot be used when the optional Network Pack KA-DV300 is used. (E MODEL)

Charging the Battery Pack

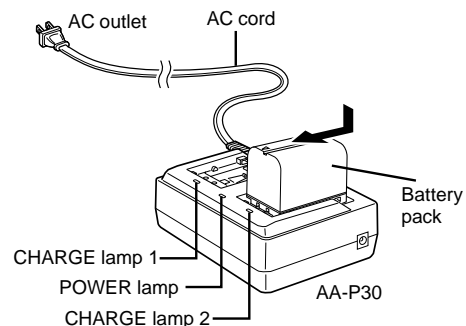

Before use the battery pack should be charged using the provided AC Adapter/Charger AA-P30.

1. Plug the AC cable of the AC Adapter/Charger into an AC outlet. The POWER lamp illuminates.
2. While pushing the battery pack down, slide it in the direction of the arrow to mount it on the AC Adapter/Charger. Charging starts, and the CHARGE lamp blinks green. It changes to light steadily when charging is completed.
3. When charging is completed, remove the battery by sliding it in the opposite direction of the mounting direction.

* For details, see the instruction manual for the AA-P30.

Attaching the Battery Pack on the GY-DV300

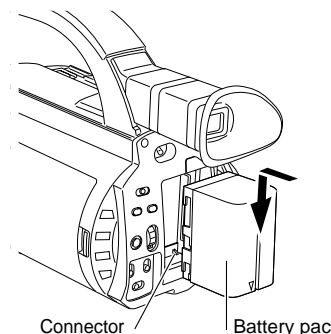

- If the DC cable is connected to the GY-DC300, unplug the cable.

1. Hold the battery pack with the connector side facing the GY-DC300.
2. While pressing the battery pack against the GY-DC300, slide it downward to attach it to the GY-DV300.

Detaching the Battery Pack from the GY-DV300

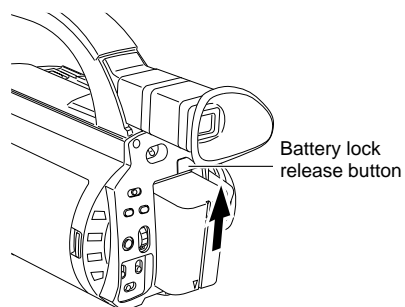

- Ensure that the POWER switch on the GY-DV300 is set to OFF.

1. While pressing the battery lock release button, slide the battery pack upward to remove it.

CAUTION:

Do not detach the battery pack while recording is taking place.

Battery Pack Operation (Cont'd)

Remaining Battery Power Indication

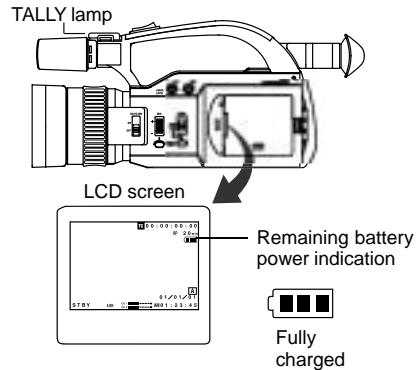

The remaining battery power condition can be checked by the remaining battery power indication on the LCD screen and the TALLY lamp. The battery condition is indicated as shown in the table below. Prepare for battery pack replacement in accordance with the indications.

Indication		Remaining Battery Power
LCD Screen	Tally Lamp	
	—	Remaining battery power is low. Prepare or replace with a fully charged battery pack.
	—	Remaining battery power is low. Prepare or replace with a fully charged battery pack.
	Slow blinking (1 blink per second)	No remaining battery power. Immediately replace with a fully charged battery pack.
	Blinking	No remaining battery power. Immediately replace with a fully charged battery pack.

After the remaining battery power indication starts blinking, recording can be continued for approx. 5 minutes. (when BN-V428 is used)

After the no remaining battery power warning appears, the GY-DV300 automatically stops operation if the battery power operation is continued.

Operating Time with Battery Pack

Battery Pack	Continuous Operating Time (25°C)	
	GY-DV300 only	When KA-DV300 in use
BN-V428	Approx. 120 min.	Approx. 80 min.

When a fully charged battery pack is attached, the approximate continuous operating time is as shown in the table on the left.

- Battery operating time may differ depending on the number of times the battery has been charged, charging conditions and the operating environment, etc. Regard the values in the table on the left as approximate reference times.
- Operating time is reduced in areas with a cold environment.
- Operating time is reduced when the power zoom lens is used frequently and when start/stop of recording is performed frequently.

PRECAUTIONS FOR THE BATTERY PACK

- When the battery pack is not in use, it must be stored in a cool, dry place. Do not leave the battery pack in a place where it might be subject to high temperatures (under direct sunlight in a car, etc.), as this could cause battery leakage or shorten the service life.
- When the terminal section of the battery pack gets dirty, the operating time will be shortened.
- If the operating time becomes greatly reduced even immediately after recharging, the service life of the battery pack is nearly finished. Purchase a new battery pack.

Recharging

- Recharge the battery pack after completely discharging it. Repeated recharging with residual charge remaining could result in reduced battery capacity.
- If the battery capacity is reduced by repeating incomplete recharging, or recharging without discharging, once discharge the battery pack completely, then recharge it to restore the battery capacity.
- If the battery pack is recharged with its internal temperature raised immediately after use, recharging may not be performed completely.

PREPARATIONS Attaching the Microphone (optional)

Using the optional KA-A33 microphone holder allows the optional microphone MV-P615U (phantom microphone) to be attached.

Mount the microphone holder on the microphone holder attachment base on the handle of the GY-DV300.

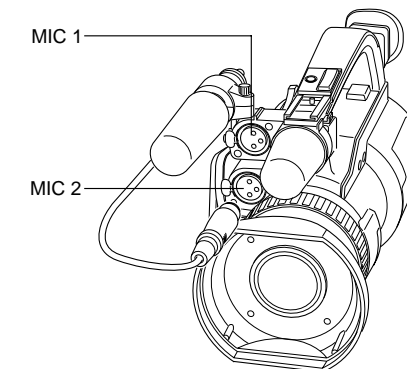
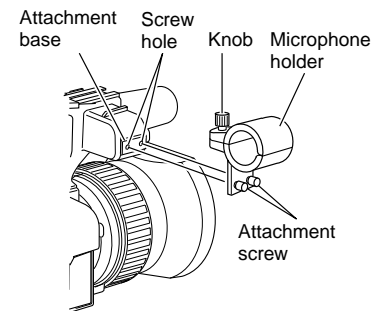
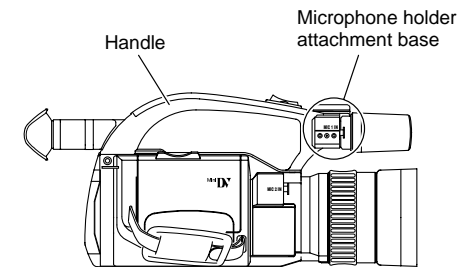

How to Attach

1. Mount the microphone holder on the microphone holder attachment base on the handle of the GY-DV300.
 - ① Loosen the attachment screw on the microphone holder.
 - ② Fasten the attachment screw on the microphone holder to secure the holder to the GY-DV300.
2. Turn the knob on the microphone holder anticlockwise to loosen it and open the microphone holder.
3. Place the microphone in the microphone holder. Place the microphone toward the front to prevent it from interfering with the cassette cover.
4. Turn the knob on the microphone holder clockwise to secure the microphone.
5. Connect the microphone cable to the MIC 1 or MIC 2 input connector on the GY-DV300.
6. Make sure to perform the correct setting for use of a phantom microphone. (See page 50.)

Memo:

When using a microphone connected to the MIC 1 input connector, set the MIC1 INPUT SEL item to XLR on the SYSTEM [1/2] menu screen.

PREPARATIONS FOR OPERATION Turning the Power ON

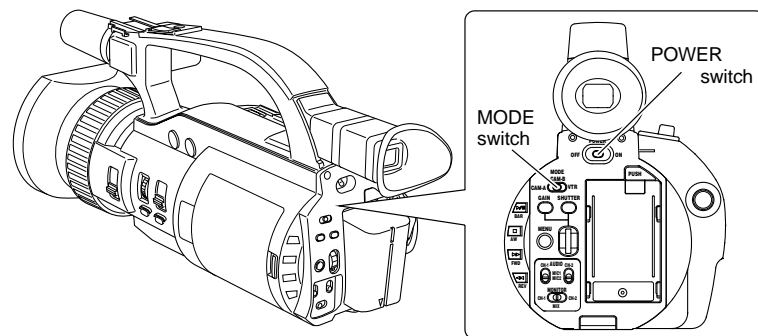

- Slide the POWER switch to "ON".
Power is now supplied to the unit.

- The GY-DV300 operation mode when the power is turned ON will differ depending on the setting of the MODE switch as described in the following:

MODE Switch	Operation Mode
"CAM-A" or "CAM-B"	The GY-DV300 starts up in the shooting mode. The camera image appears in the viewfinder or on the LCD screen. When a recordable videocassette is loaded, the GY-DV300 enters the recording-standby mode automatically. "STBY" is displayed in the VTR operation mode indication area on the LCD screen and the viewfinder screen. In this condition, press the REC START/STOP button to start recording.
VTR	The GY-DV300 starts up in the VTR playback mode. The camera image does not appear in the viewfinder or on the LCD screen. If videocassette is loaded, the mode will be the STOP mode. "STOP" is indicated in the section for displaying the VTR operation mode on the LCD screen or viewfinder screen.

Turning the Power OFF

- Place the GY-DV300 in the recording-standby or STOP mode.
- Slide the POWER switch to "OFF".
- Remove the battery pack or the power supply to the DC INPUT connector. (When the GY-DV300 is not going to be used for a long time.)

CAUTION:

- Do not set the POWER switch to "OFF" while recording is taking place. Confirm that the STBY or STOP indication is shown in the VTR operation mode indication area before the power is turned off. Should the POWER switch accidentally be set to "OFF" during a recording, wait at least 5 seconds before turning the power on again.
- Before the power supply is disconnected, be sure to set the GY-DV300's POWER switch to "OFF". If the battery is removed or the power supply from the AC adapter is disconnected while the GY-DV300's POWER switch is set to "ON", the manual mode operation setting values (IRIS, zoom, gain, shutter speed, white balance, etc.) are not backed up.

TENTATIVE

PREPARATIONS FOR OPERATION Cassette Loading

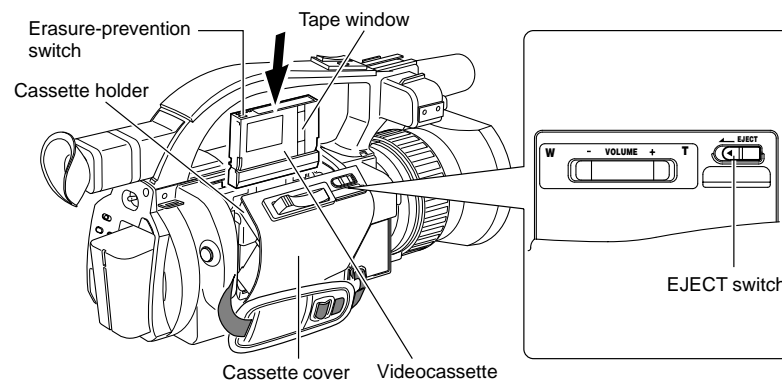

Loading the Cassette

Use a videocassette tape marked MiniDV.

- To record, slide the switch on the back for use in preventing accidental erasure to the "REC" side.
 - Remove any the tape slack before loading.
- Slide the EJECT switch on the top section of the GY-DV300 and then open the cassette cover.
 - Insert a videocassette into the cassette slot. With the window in the cassette facing outward and the erasure-prevention switch up, push down on the center section of the cassette back, ensuring that the cassette is inserted straight and all the way.
 - Slowly push the "PUSH HERE" section on the cassette holder with a finger until a click is heard. Confirm that the cassette holder does not come up when you remove your finger.
 - Gently close the cassette cover by pushing it in all the way.

- When the power is turned on, the condition varies as shown in the following table.

MODE Switch	Erasure-Prevention Switch Position	
	REC	SAVE
CAM A or CAM B	Recording-standby mode	STOP mode. REC INHIBIT displayed on the LCD screen and the viewfinder screen.
VTR	STOP mode	

* After the cassette cover is closed, it takes about 11 seconds before the unit can start recording or before it enters the STOP mode.

Unloading the Cassette

- In the recording-standby or STOP mode, slide the EJECT switch to the side and then fully open the cassette cover.
 - Tape ejection starts. It takes a few seconds before the cassette is ejected.
- Take out the videocassette.
- Close the cassette cover.

CAUTION:

- Do not slide the EJECT switch during recording. If the EJECT switch is slid during recording, the tape is ejected.
- Do not leave the unit for a long period with the cassette cover open. Dirt or other foreign objects may enter the unit and cause malfunction.
- When the cassette tape is inserted, press the "PUSH HERE" section on the cassette holder to lock the cassette holder properly. Then close the cassette cover. Refrain from repeatedly raising and lowering the cassette holder when the cassette holder is not completely locked. The tape could become slack as a result of the operation.

PREPARATIONS FOR OPERATION LCD Screen Adjustment

The LCD screen's direction, angle, screen brightness, etc. can be adjusted.

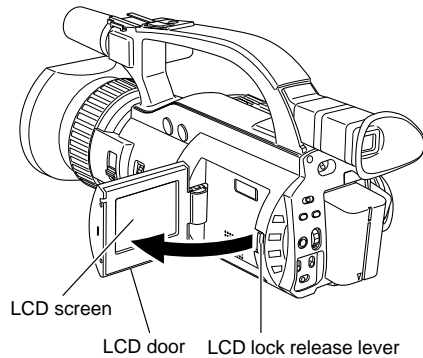

■ Viewing the LCD Screen

Slide the LCD lock release lever toward the rear side to open the LCD door.

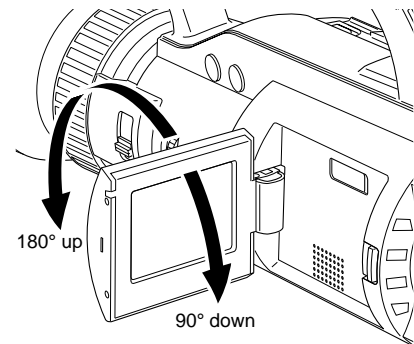

■ Adjusting the Direction and Angle of the LCD Screen

- With the LCD door in the open condition, rotate the LCD door.

It can be turned 180° in upward direction and 90° in downward direction.

When turned 180° in upward direction, the LCD screen can be viewed from the lens side (vertically inverted image).

DISPLAY [1/2] menu screen

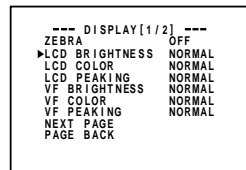

■ Adjusting the LCD Screen

Adjustments are made on the DISPLAY [1/2] menu screen.

(See "Setting Menu Screens" on page 94.)

- LCD BRIGHTNESS: Adjusts the brightness of the LCD screen.
- LCD COLOR: Adjusts the color saturation of the LCD screen.
- LCD PEAKING: Adjusts the contrast of the LCD screen.

■ Closing the LCD Screen

Return the direction of the LCD screen to the normal position, and then close it into the camera body.

PREPARATIONS FOR OPERATION Adjusting the Viewfinder

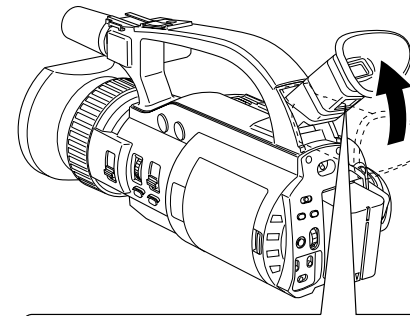

■ Adjusting the Position of the Viewfinder

To facilitate low-angle shooting, the viewfinder can be turned approximately 75° upward.

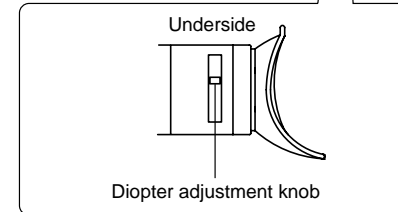

■ Diopter Adjustment

Move the diopter adjustment knob on the underside of the viewfinder until the viewfinder screen image is clearly visible.

DISPLAY [1/2] menu screen

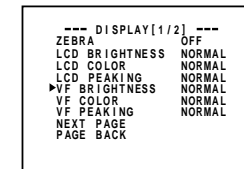

■ Adjustment of the Viewfinder Image

Adjustments are made on the DISPLAY [1/2] menu screen.

(See "Setting Menu Screens" on page 94.)

- VF BRIGHTNESS: Adjusts the brightness of the viewfinder screen.
- VF COLOR: Adjusts the color saturation of the viewfinder screen.
- VF PEAKING: Adjusts the contrast of the viewfinder screen.

Setting, Displaying and Recording the Date and Time

PREPARATIONS FOR OPERATION

The date and time of the built-in clock should be set. Powered by the built-in rechargeable backup battery, the set date and time data are retained and continue to count even when the power is switched off.

- Whether to display the set date and time data on the LCD screen or the viewfinder screen or record it on the tape can be specified by settings on the menu screen.

Setting the Date and Time

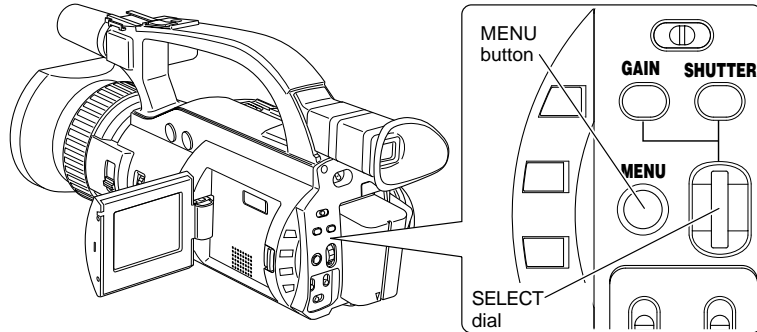

TOP MENU screen

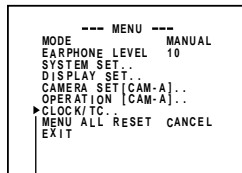

Cursor

CLOCK/TC menu screen

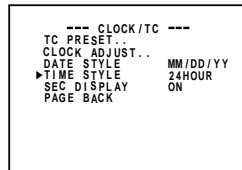

Memo:
The TIME STYLE, SEC DISPLAY and DATE STYLE items can also be set or changed after setting of the date and time is completed.

- The date and time and time code are set on the CLOCK/TC menu screen.

Make the settings while observing the LCD screen or a monitor connected to the VIDEO OUT connector. When making the settings while observing a monitor connected to the VIDEO OUT connector, set the OUTPUT CHAR. item on the DISPLAY [2/2] screen menu to MIX.

1. Set the POWER switch to "ON".
2. Press the MENU button to display the TOP MENU screen.
3. Rotate the SELECT dial to align the cursor (▶) with the CLOCK/TC item, and then press the SELECT dial in the direction of the camera body.
 - The CLOCK/TC menu screen appears.
4. Make settings on the CLOCK/TC menu screen. (This includes display style, etc.)

- DATE STYLE** : Selects the style for displaying the date.
YY/MM/DD (Year, month, day)
MM/DD/YY (Month, day, year)
DD/MM/YY (Day, month, year)
- TIME STYLE** : The time can be set to display as a 12-hour or 24-hour clock system.
- SEC DISPLAY** : To select whether or not the second indication should be displayed on the screen. However, regardless of this setting, the seconds are set when the date and time are set.

TENTATIVE

Setting, Displaying and Recording the Date and Time (cont'd)

PREPARATIONS FOR OPERATION

CLOCK/TC menu screen

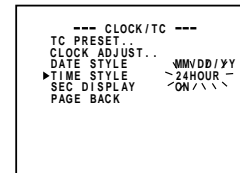

CLOCK/TC menu screen

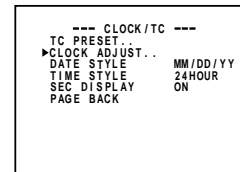

Date (Month, day, year)

CLOCK ADJUST menu screen

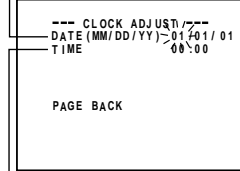

Time (Hour, min, sec)

CLOCK ADJUST

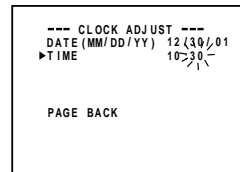

Normal screen

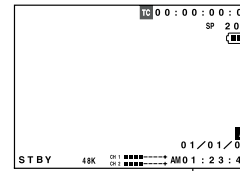

Date time indication
(Selected on the DISPLAY [2/2] menu screen)

1. Rotate the SELECT dial to align the cursor (▶) with the item to be set, and then press the SELECT dial.
 - The setting area of the selected item starts blinking.
2. Rotate the SELECT dial to change the setting, and then press the SELECT dial.
 - The setting area stops blinking and the setting is entered.

5. Display the screen for setting the date and time. Rotate the SELECT dial to align the cursor (▶) with the CLOCK ADJUST item, and then press the SELECT dial.
 - The CLOCK ADJUST screen appears.

6. Set the date and time. The blinking digit is the one to be set.
 1. When the SELECT dial is pressed, the blinking digit changes.
 2. When the SELECT dial is rotated, the value of the blinking digit changes. When the SELECT dial is rotated upward, the value becomes higher. When rotated downward, the value becomes smaller.
 3. Repeat the procedure described in 1 and 2 above to set the month, day, year, hours, minutes. The digits indicating seconds cannot be set.
 4. Press the SELECT dial in sync with a time signal to enter the date and time precisely.

7. When all the settings are completed, rotate the SELECT dial to align the cursor with the PAGE BACK item, and then press the SELECT dial.
 - The CLOCK/TC menu screen returns.

8. To return to the normal screen, use either of the following methods. Press the MENU button or Return to the TOP MENU screen and then select the EXIT item from the TOP MENU screen before pressing the SELECT dial.

Displaying the Time and Date on the Screen

Whether or not the time and date should be displayed on the screen is set with the TIME/DATE item on the DISPLAY [2/2] menu screen. The display style is selected by setting the DISP STYLE item.

DISPLAY [1/2] menu screen

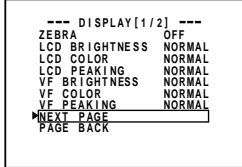

DISPLAY [2/2] menu screen

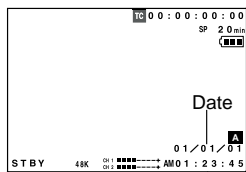
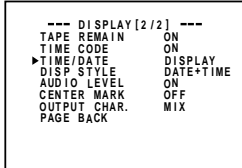

Time

Recording the Date and Time Data

To record the date and time during shooting, set the following menu items.

- Recording of the date and time data may be interrupted momentarily if the LCD screen is turned to faced toward the lens (reversed display) during recording of the date and time data.

When the ASPECT ratio is set to LETTER, the date and time indication is not recorded.

SYSTEM [2/2] menu screen

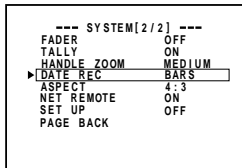

1. Display the DISPLAY [2/2] menu screen.

- Select the DISPLAY SET item on the TOP MENU screen.
- Select the NEXT PAGE item on the DISPLAY [1/2] menu screen.

2. Set the TIME/DATE item on the DISPLAY [2/2] menu screen.

DISPLAY : The date and time are displayed on the LCD screen or the viewfinder screen.

The indications are not recorded on the tape.

DISP+REC : The date and time are displayed on the LCD screen or the viewfinder screen and are recorded on the tape.

OFF : The date and time are not displayed and are not recorded on the tape.

3. The display style is selected by setting the DISP STYLE item on the DISPLAY [2/2] menu screen.

DATE+TIME : Both date and time are displayed.

DATE : Date only is displayed.

TIME : Time only is displayed

■ Display of date and time in the various operation modes.

In shooting mode : The date and time of the internal clock are displayed.

In VTR playback mode : The date and time recorded on the tape are displayed.

In VTR stop mode : The date and time of the internal clock are displayed.

During DV signal input: The date and time from the DV (U MODEL) connector are displayed.

PREPARATIONS FOR OPERATION Charging the Built-in Battery

The built-in, rechargeable backup battery retains the date and time and the time code data. The built-in battery is constantly being charge whenever the GY-DV300 is connected to a power supply, but it gradually discharges while the GY-DV300 is disconnected from a power supply. The battery will be fully discharged when the GY-DV300 is not used for about three months, in which case the set date and time and time code data are reset. In this case, recharge the built-in battery and then set the date and time and time code data again.

However, it is possible to use the GY-DV300 even if the built-in battery is discharged but the date and time and time code data cannot be recorded.

■ How to charge

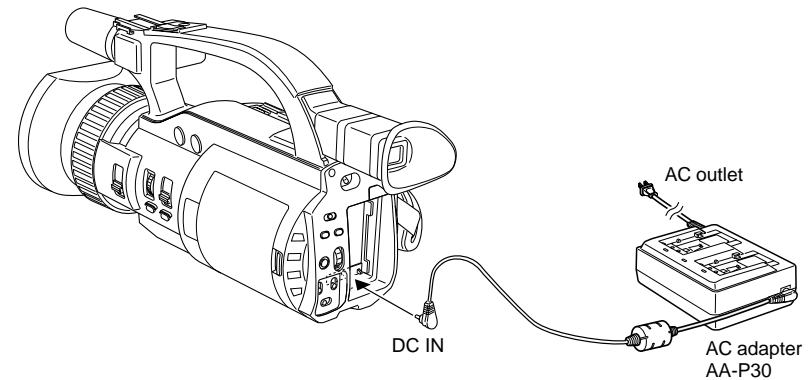

- Connect the provided (U MODEL)/optional (E MODEL) AC adapter AA-P30 to the GY-DV300 and an AC outlet or mount a charged battery on the GY-DV300.
- Set the POWER switch on the GY-DV300 to "OFF" or "ON" (charging takes places with the POWER switch set to either of the positions.)
- Leave the equipment in this condition for about 4 hours.
 - The built-in battery will remain charged for about 3 months after being charged for about 4 hours.

Setting, Displaying and Recording the Time Code

PREPARATIONS FOR OPERATION

Time code data should be set in the built-in time code generator. User's bits cannot be set. During recording, the time code is automatically recorded on the tape.

When recording starts from the beginning of the tape, recording starts from the set time code.

Presetting the Time Code

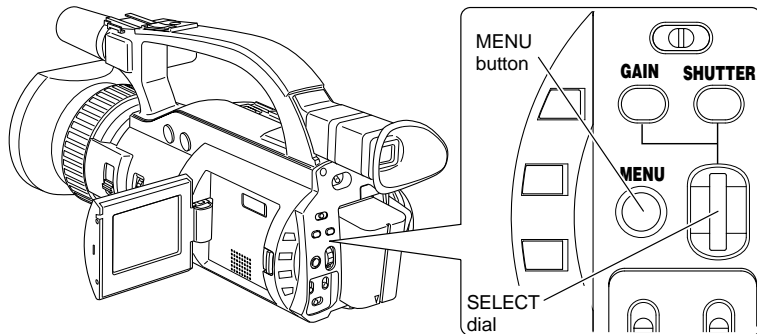

CLOCK/TC menu screen

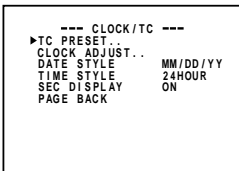

The time code is preset on the CLOCK/TC menu screen.

1. Display the CLOCK/TC menu screen.
To display the CLOCK/TC menu screen, perform the operations described in steps 1 to 3 in "Setting the Date and Time" on page 41.

2. Rotate the SELECT dial to align the cursor (▶) with the TC PRESET item, and then press the SELECT dial.
• The TC PRESET screen appears.

3. Set the time code (hours, minutes, seconds, frames).
The blinking digit is the one to be set.

- ① When the SELECT dial is pressed, the blinking digit changes.
- ② When the SELECT dial is rotated, the value of the blinking digit changes.
When the SELECT dial is rotated upward, the value becomes higher. When rotated downward, the value becomes smaller.
- ③ Repeat the procedure described in ① and ② above to set the desired value for all digits.
- ④ The setting values are confirmed and entered when the frame digit blinks and the SELECT dial is pressed.

4. When setting of all the digits is completed, rotate the SELECT dial to align the cursor with the PAGE BACK item, and then press the SELECT dial.

- The CLOCK/TC menu screen returns.

TC PRESET screen

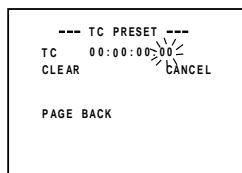
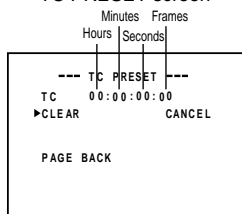

TENTATIVE

Setting, Displaying and Recording the Time Code (cont'd)

PREPARATIONS FOR OPERATION

To zero-set the time code

- ① Rotate the SELECT dial to align the cursor with the CLEAR item, and then press the SELECT dial.
- ② Rotate the SELECT dial to set the CLEAR item to EXECUTE, and then press the SELECT dial.

5. To return to the normal screen, use either of the following methods.

Press the MENU button

or

Return to the TOP MENU screen and then select the EXIT item from the TOP MENU screen before pressing the SELECT dial.

Memo:

The preset time code value is reset when the power is turned off.

Displaying the Time Code on the Screen

Whether or not the time code should be displayed on the screen is set with the TIME CODE item on the DISPLAY [2/2] menu screen.

DISPLAY [2/2] menu screen

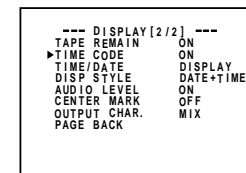

1. Display the DISPLAY [2/2] menu screen.

- ① Select the DISPLAY SET item on the TOP MENU screen.
- ② Select the NEXT PAGE item on the DISPLAY [1/2] menu screen.

2. Set the TIME CODE item on the DISPLAY [2/2] menu screen.
To display the time code, set the item to ON.

■ **Display of the time code in the various operation modes.**
In shooting mode : The current value of the built-in time code generator is displayed.

In VTR playback mode : The time code recorded on the tape is displayed.

During DV signal recording (U MODEL) : The current value of the built-in time code generator is displayed.

Time code indication

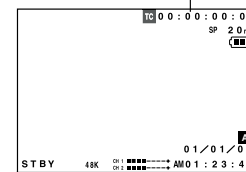

Recording the Time Code

The time code is recorded on the tape during recording. The time code formats are fixed as drop frame (U MODEL), and regeneration mode.

Drop frame : Time code data matching the actual time. (U MODEL)

REGEN : The time code already recorded on the tape is read, and the time code is recorded in continuation of the existing data. It will start from "00" if there is no time code recorded at the location where the recording is started.

Memo:

- The time code recorded at the beginning of a tape may not be read.
- The preset time code is only valid when recorded from the beginning of the tape. (REC RUN operation only)
REC RUN: The time code starts counting from when recording is started.

SETTINGS BEFORE SHOOTING

Shooting Mode (Auto/Manual) Selection

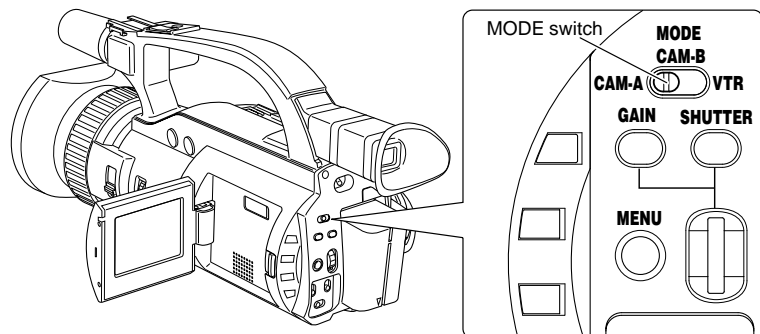

TOP MENU screen

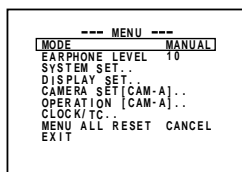

The GY-DV300 is provided with two positions, "CAM-A" and "CAM-B", for registering mode settings for camera shooting. Settings made on separate menu screens for camera shooting can be allocated to each of the "CAM-A" and "CAM-B" mode positions. Also, the GY-DV300 offers two shooting modes, AUTO and MANUAL, which are selected by setting the MODE item on the TOP MENU screen. The AUTO or MANUAL shooting mode can be set separately for each of the "CAM-A" and "CAM-B" mode positions.

About the AUTO and MANUAL Shooting Modes

In the AUTO shooting mode, the settings OPERATION menu screen items will be those valid for the auto mode.

Menu Contents	OPERATION Menu Screen
Mode	For setting iris, shutter speed, gain, white balance, audio recording level, and camera-shake compensation.
AUTO shooting	The GY-DV300 is adjusted automatically.
MANUAL shooting	Make settings as desired on the OPERATION menu screen. Adjustments can be made using the GY-DV300's operation buttons and dial, etc.

SETTINGS BEFORE SHOOTING

Shooting Mode (Auto/Manual) Selection (cont'd)

How to Select Either MANUAL or AUTO Shooting Mode

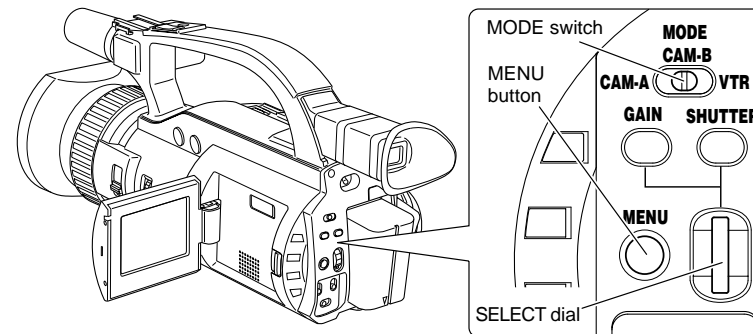

TOP MENU screen

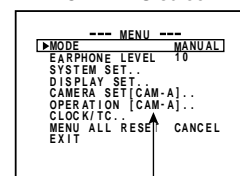

Indication of set position of the MODE switch

- When the MODE item is set to MANUAL, the position of the MODE switch ("CAM-A" or "CAM-B") is indicated after the CAMERA SET and OPERATION SET items. The settings are valid for the position indicated for the MODE switch.
- When the MODE item is set to AUTO, the OPERATION SET items are not displayed. The position of the MODE switch ("CAM-A" or "CAM-B") is indicated after the CAMERA SET item.

1. Set the MODE switch to the "CAM-A" or "CAM-B" position.
2. Press the MENU button to display the TOP MENU screen.
3. Rotate the SELECT dial to align the cursor (▶) with the MODE item, and then press the SELECT dial.
 - The MODE item setting area is seen blinking, and settings can now be changed.
4. Rotate the SELECT dial to set to AUTO or MANUAL.
 - AUTO** : Auto shooting mode
 - MANUAL** : Manual shooting mode
5. Press the SELECT dial.
 - The setting area stops blinking and the setting is confirmed and entered.
6. Rotate the SELECT dial to align the cursor (▶) with the EXIT item, and then press the SELECT dial.
 - The normal screen returns.

TENTATIVE

SETTINGS BEFORE SHOOTING

Audio Input Signal Selection

The GY-DV300 is provided with three sources for audio input (i.e., built-in microphone and input connectors MIC 1 and MIC 2 for external microphones).

Two channels of sound can be recorded on the tape in digital PCM format. Select for each channel (CH1 and CH2) which sound should be recorded on the channel. The sound of each of the input sources is monaural.

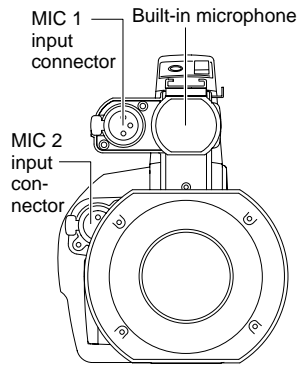

Select whether the built-in microphone or a microphone connected to the MIC 1 input connector should be used.

The built-in microphone and a microphone connected to the MIC 1 input connector cannot be used at the same time.

When using the GY-DV300 with the built-in microphone or a microphone connected to the MIC 1 input connector, select which one to use by setting the MIC1 INPUT SEL item on the SYSTEM [1/2] menu screen.

SYSTEM [1/2] menu screen

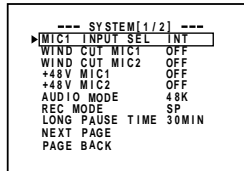

- Set to INT to use the built-in microphone.
- Set to MIC 1 to use the microphone connected to the XLR input connector.

Select the input signal to the CH-1, CH-2 audio channels

The audio signal input to the CH-1, CH-2 audio channels is selected with the AUDIO input selector switch.

The input can be set separately for each channel.

Setting	Input Signal
MIC 1	The microphone sound from the built-in microphone or a microphone connected to the MIC 1 input connector. (Make the selection with the MIC1 INPUT SEL item on the SYSTEM [1/2] menu screen.)
MIC 2	The microphone sound from a microphone connected to the MIC 2 input connector.

The same sound can be input to both the CH-1 and CH-2 channels.

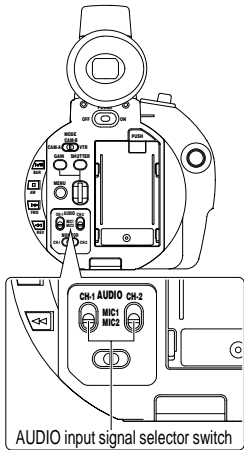

TENTATIVE

SETTINGS BEFORE SHOOTING

Audio Input Signal Selection (cont'd)

Setting Whether Phantom Microphone Should be used as External Microphone

SYSTEM [1/2] menu screen

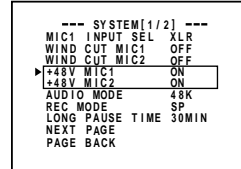

When a microphone (phantom microphone) requiring +48V DC power supply is connected, set the +48V MIC1 or +48V MIC2 items on the SYSTEM [1/2] menu screen.

+48V MIC1: Setting for the microphone connected to the MIC 1 input connector.

+48V MIC2: Setting for the microphone connected to the MIC 2 input connector.

- Set to ON when a phantom microphone is used.
- Set to OFF when other microphone type than phantom microphone is used.

CAUTION:

- Confirm that the +48V MIC1 or +48V MIC2 items are set to OFF before connecting another microphone type than phantom microphone.
- When the setting of the +48V MIC1/MIC2 item is changed, noise will appear in the sound but this is normal.

SETTINGS BEFORE SHOOTING **Audio Monitor Selection**

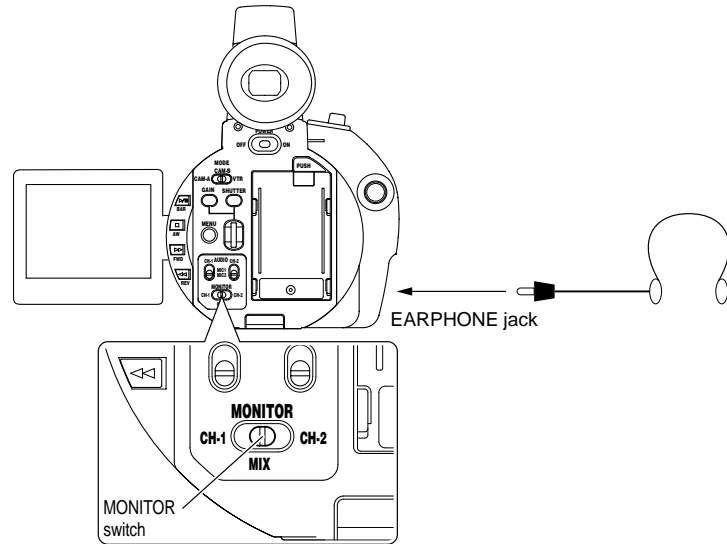

The audio input in the shooting mode can be monitored through an earphone or headphones connected to the EARPHONE jack.

The audio monitor output signal is monaural.

* In the shooting mode, sound is not output from the built-in speaker.

■ **Select the audio channel to be monitored using the MONITOR switch.**

“CH-1” : The signal input to the CH-1 channel is output.

“MIX” : The sound input to the CH1 and CH2 channels is output mixed.

“CH-2” : The signal input to the CH-2 channel is output.

■ **The volume of the monitor sound in the shooting mode is set with the EARPHONE LEVEL item on the TOP MENU screen. (☞ See page 90.)**

TOP MENU screen

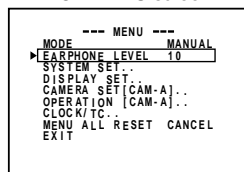

SETTINGS BEFORE SHOOTING **Focus Mode Selection**

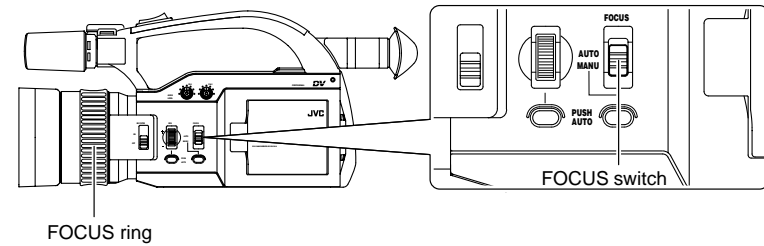

The FOCUS switch is used to select whether focus adjustment should take place in the auto mode or the manual mode.

FOCUS Switch	Focus Adjustment
AUTO	The auto focus function will be operating and the camera automatically focuses on the subject.
MANU	The focus is manually adjusted by turning the FOCUS ring on the lens section. For manual focusing, ☞ see page 63.

Depending on the subject and the shooting conditions, focusing may not be obtainable in the auto focus mode. In this case, adjust the focus in the manual mode.

SETTINGS BEFORE SHOOTING

Angle of View (Zoom In/Zoom Out)

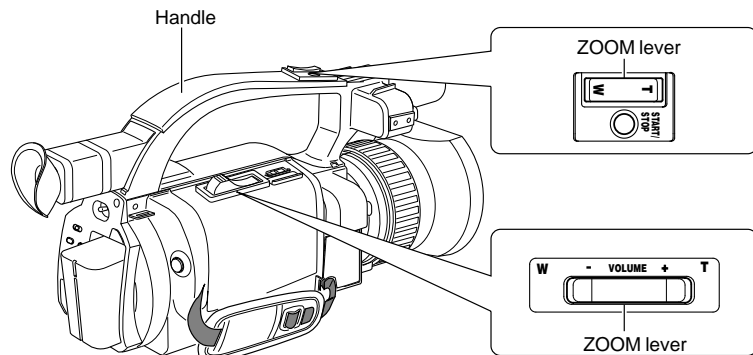

The ZOOM lever is used for zoom-in and zoom-out operations. Zooming can be performed using either the ZOOM lever on the top section of the GY-DV300 or the ZOOM lever on the top of the handle section.

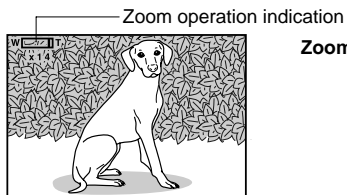

Zoom-in : The subject becomes larger (max. 14 times)

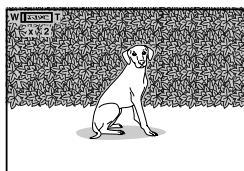

Zoom-out : The subject becomes smaller and the picture angle wider.

Memo:
During zooming, the zoom position and zoom ratio are indicated on the LCD screen and the viewfinder screen.

Zooming

- Set the MODE switch to “CAM-A” or “CAM-B”.
- To zoom in, press the ZOOM lever toward the “T” side.
- To zoom out, press the ZOOM lever toward the “W” side.

SYSTEM [2/2] menu screen

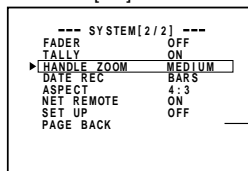

- When the zoom lever on the top section is pushed lightly, the zoom speed will be slow; and when pushed hard, the zoom speed will be fast.
- The zoom speed of the ZOOM lever on the handle section is selected by setting the HANDLE ZOOM item on the SYSTEM [2/2] menu screen. (SLOW/MEDIUM/FAST).

TENTATIVE

SETTINGS BEFORE SHOOTING

Menu Screen Settings

The various conditions under which shooting should take place are set on the SYSTEM menu screen. The SYSTEM menu screen consists of two screens. (The SYSTEM menu screen settings must be made regardless of whether the AUTO or MANUAL shooting mode is used.)

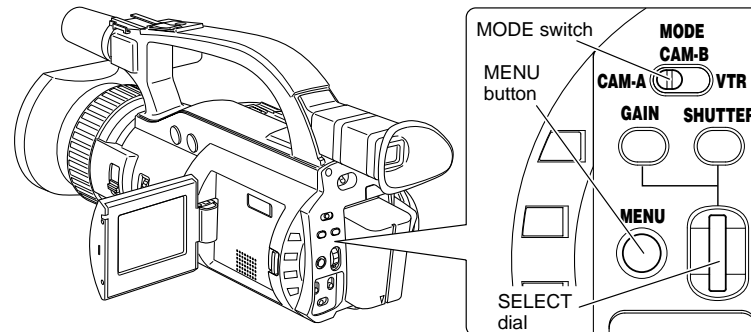

Opening the SYSTEM menu screen

TOP MENU screen

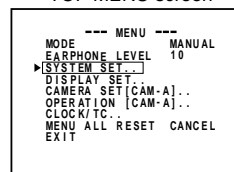

SYSTEM [1/2] menu screen

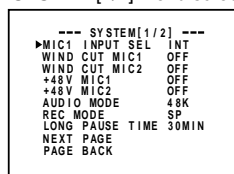

SYSTEM [2/2] menu screen

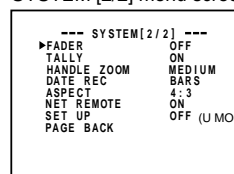

1. Set the MODE switch to “CAM-A” or “CAM-B”.
2. Press the MENU button to display the TOP MENU screen.
3. Rotate the SELECT dial to align the cursor (▶) with the SYSTEM SET item, and then press the SELECT dial.
 - The SYSTEM [1/2] menu screen appears.
4. Rotate the SELECT dial to align the cursor (▶) with the item to be set, and then press the SELECT dial.
 - The setting area of the selected item starts blinking, and the set value can now be changed.
5. Rotate the SELECT dial to change the setting, and then press the SELECT dial.
 - The setting area stops blinking and the setting is entered.
6. Repeat the steps 3 to 5 above to change other items.
7. To display the SYSTEM [2/2] menu screen, align the cursor (▶) with the NEXT PAGE item, and then press the SELECT dial.
8. When settings on the SYSTEM menu screen are completed, rotate the SELECT dial to align the cursor (▶) with the PAGE BACK item, and then press the SELECT dial.
 - The original menu screen returns.
9. To return to the normal screen, use either of the following methods.
 - Press the MENU button
 - or
 - Return to the TOP MENU screen and then select the EXIT item from the TOP MENU screen before pressing the SELECT dial.

SETTINGS BEFORE SHOOTING **Menu Screen Settings (cont'd)**

Contents of Settings on the SYSTEM [1/2] Screen

Item	Contents of Setting
MIC1 INPUT SEL	Selects whether the built-in microphone or a microphone connected to the MIC 1 input connector should be used. INT : Use this setting when the built-in microphone should be used. XLR : Use this setting when a microphone connected to the MIC 1 input connector should be used.
WIND CUT MIC1	Selects whether or not the wind noise picked up by the internal microphone or a microphone connected to the MIC 1 input connector is reduced. (ON/OFF)
WIND CUT MIC2	Selects whether or not the wind noise picked up by a microphone connected to the MIC 2 input connector is reduced. (ON/OFF)
+48V MIC1/+48V MIC2	Sets whether +48 V power should be supplied to a microphone connected to the MIC 1 or MIC 2 input connector. (MIC 1 and MIC 2 are set separately.) This should only be set to ON when a phantom microphone is used.
AUDIO MODE	Selects the sampling frequency for audio recording (32 kHz or 48 kHz). * 4 channels are available when the DV format is recorded with 12-bit, 32 kHz sampling, but the GY-DV300 records the CH-1 and CH-2 channels. The GY-DV300 does not allow after-recording.
REC MODE	Selects the recording speed mode. SP : Standard Play recording mode. LP : Long Play recording mode (recording time is 1.5 times longer than in the SP mode.) * Tapes recorded in the LP mode on the GY-DV300 can only be played back on this unit. When playing back on another unit, noise will appear in the picture and the sound.
LONG PAUSE TIME	Selects the time (minutes) before the tape protection mode (drum automatically stops rotating) is engaged when the recording pause (the recording-standby mode) or still mode continues. (3 minutes or 30 minutes.) When used in a cold environment, this becomes 3 minutes regardless of the setting.

Contents of Settings on the SYSTEM [2/2] Menu Screen

Item	Contents of Setting
FADER	Sets whether fade is performed when recording is started and stopped. OFF : No fade. BLACK : Fade in from black screen when recording is started; fade out to black screen when recording is stopped.
TALLY	Selects whether the tally lamp lights during recording. Set to OFF to prevent the tally lamp from lighting during recording.
HANDLE ZOOM	Sets the zoom speed when the ZOOM lever on the handle section is used. Select between three speeds. (SLOW/MEDIUM/FAST)
DATE REC	Select the mode in which the date and time data should be recorded. BARS : Date and time data are recorded only when color bars are output. BARS+CAM : Date and time data are recorded only when color bars and camera image are output. • When the date and time data should be recorded, the TIME/DATE item must be set to DISP+REC on the DISPLAY [2/2] menu screen.
ASPECT	The screen size of recorded images can be selected. 4:3 : To record with the normal screen size with an aspect ratio of 4:3. LETTER : To record with a LETTER BOX screen with an aspect ratio of 16:9 where the upper and lower part of the image is cut off.
SET UP (U MODEL)	Selects whether the composite video and Y/C separate signal should be provided with the setup level at the time of recording and playback. (ON/OFF)

SHOOTING Basic Recording Operation

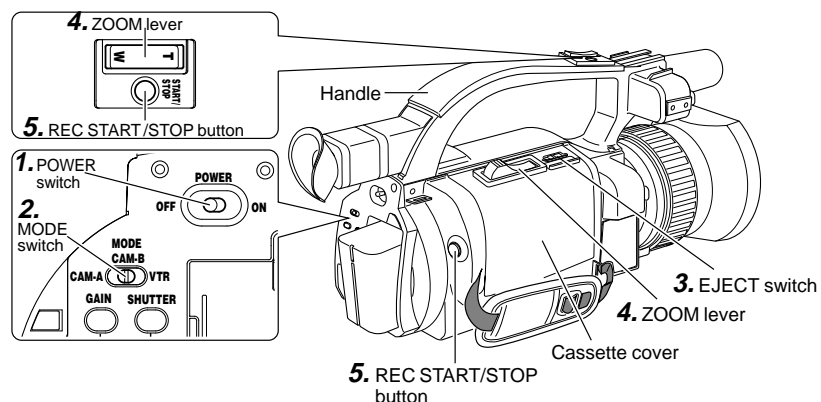

- **Setting the recording mode (AUTO/MANUAL)**
The recording mode is set by means of the MODE item on the TOP MENU screen. (See page 47, 48.)

This section explains the basic recording procedures when the AUTO mode is selected as the shooting mode.

1. Set the POWER switch to "ON".
Power is supplied to the unit.
2. Set the MODE switch to "CAM-A" or "CAM-B".
The GY-DV300 enters the shooting mode.
 - The set values indicated on the menu screen will be either those of "CAM-A" or "CAM-B" in accordance with the setting of the MODE switch.
3. Slide the EJECT switch to open the cassette cover.
Ensure that the erasure-prevention switch on the back of the cassette is set to REC and insert a videocassette properly.
Slowly push the "PUSH HERE" section on the cassette holder with a finger until a click is heard. Confirm that the cassette holder does not come up when you remove your finger.

■ **The tape is loaded and the unit enters the recording-standby mode when the cassette cover is closed.**

- When the recording-standby mode is engaged, STBY is indicated as the VTR mode on the LCD screen and the viewfinder screen.

Memo:
After the cassette cover is closed, it takes about 11 seconds before the unit is ready for recording.

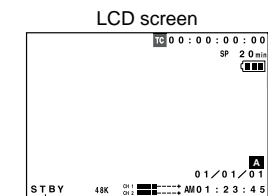

VTR mode indication

TENTATIVE

SHOOTING Basic Recording Operation (cont'd)

- **ZOOM lever**
A ZOOM lever is provided in two positions: one on the top section of the unit, and the other on top of the handle. Both can be used for zooming.
 - **REC START/STOP button**
A REC START/STOP button is provided in two positions: one on the rear section of the unit, and the other on top of the handle. Both can be used for operation.
4. Point the camera at the subject and determine the angle of view with the ZOOM lever.
 - **Adjusting the focus**
 - When the FOCUS switch is set to "AUTO", the auto-focus function will be operating and focusing is performed automatically.
 - When the FOCUS switch is set to "MANUAL", the FOCUS ring should be turned to adjust the focus. (See page 63.)
 5. Press the REC START/STOP button.
Recording starts.
 - Once recording has started, REC is indicated as the VTR mode on the LCD screen and the viewfinder screen and the TALLY lamp lights up.

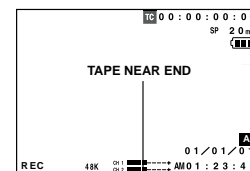

VTR mode indication

Memo:
• When remaining time for recording is less than about 3 minutes, TAPE NEAR END is displayed on the LCD screen and the viewfinder screen and the TALLY lamp blinks slowly.

CAUTION:
• Noiseless transitions between scenes cannot be guaranteed if the POWER switch is set to "OFF" or the battery is removed during a recording.

6. To stop recording, press the REC START/STOP button.
The unit rewinds the tape about 2 seconds before it enters the recording-standby mode.
The VTR mode indication changes to STBY and the TALLY lamp goes out.
7. To restart recording press the REC START/STOP button.
8. To end the recording, enter the recording-standby mode and perform the following operations as required.
 - **When it is required to unload the videocassette:**
Slide the EJECT switch.
 - **When the power should be turned off:**
Set the POWER switch to OFF.

Memo:
Whether the TALLY lamp should light during recording is selected with the TALLY item on the SYSTEM [2/2] menu screen.

SHOOTING Viewing the Recorded Scene (Edit Search)

The recorded scene can be checked and the position for recording the next scene can be searched in the recording-standby mode.

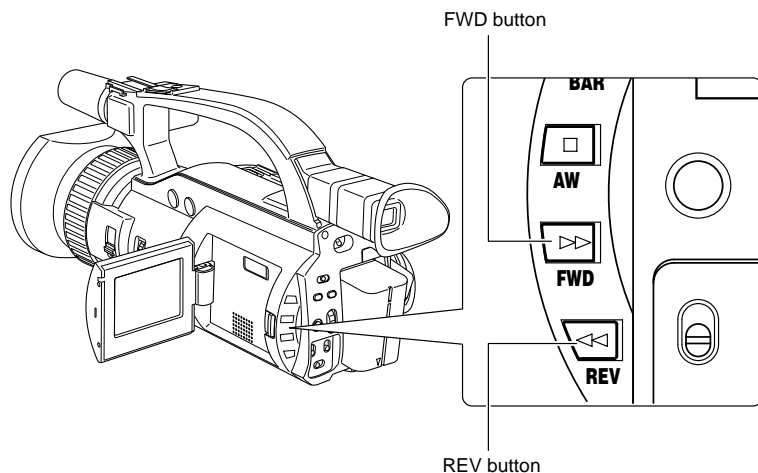

Screen indication during edit search

The VTR mode is indicated as ED.FWD or ED.REV on the LCD screen and the viewfinder screen during edit search.

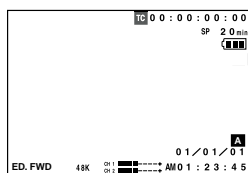

ED.FWD : Forward search
ED.REV : Reverse search

Enter the recording-standby mode

■ To advance the tape in forward direction.

1. Press the FWD button. Playback is performed at normal speed as long as the button is pressed down.
2. When the FWD button is released, the unit returns to the recording-standby mode.

■ To rewind the tape in reverse direction.

1. Press the REV button. Playback in reverse direction is performed at normal speed as long as the button is pressed down.
2. When the REV button is released, the unit returns to the recording-standby mode.

Memo:

When the recording speed mode (SP/LP) setting differs from the setting used for the part already recorded on the tape, the picture may be disturbed at the switching point.

SHOOTING If the Unit is Left in Recording-Standby Mode

Setting the time before the tape protection mode is engaged

The time before the tape protection mode is engaged from the recording-standby mode can be set as 30 minutes or 3 minutes by the LONG PAUSE TIME item on the SYSTEM [1/2] screen menu.

When the recording-standby mode has continued for about 30 minutes, the GY-DV300 automatically stops drum rotation in order to protect the tape. (Tape protect mode)

- In the tape protect mode, STOP is shown as the VTR mode indication on the LCD screen and the viewfinder screen.

■ To start recording from the tape protect mode, press the REC START/STOP button.

- The drum starts rotating, and recording starts after about 3 seconds.

■ To return to the recording-standby mode from the tape protect mode, press the REC START/STOP button twice.

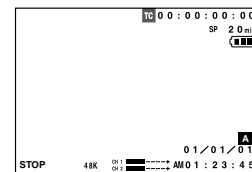

VTR mode indication

SHOOTING Recording the Color Bar

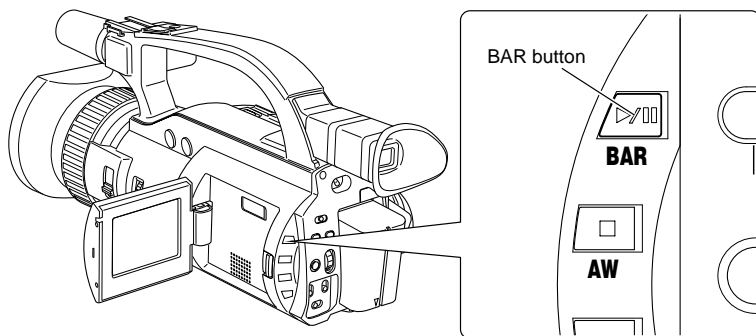

Color bar signal of the built-in signal generator

An SMPTE standard color bar is output. (U MODEL)

White	Yellow	Cyan	Green	Magenta	Red	Blue
Blue	Black	Magenta	Black	Cyan	Black	White
Black	White	Black				

An EBU standard color bar is output. (E MODEL)

White	Yellow	Cyan	Green	Magenta	Red	Blue	Black
-------	--------	------	-------	---------	-----	------	-------

It can be selected whether the camera image should be output or whether the color bar of the built-in signal generator should be output during recording-standby and recording.

■ The color bar is output when the BAR button is pressed while the camera image is output.

■ To return to the camera image, press the BAR button again.

TENTATIVE

SHOOTING Using the AE (Automatic Exposure) Function

In addition to the automatic shooting mode, the GY-DV300 also offers the use of the AE (Automatic Exposure) function. The AE function combines the following three functions to automatically adjust the video signal level to their optimum levels.

Gain : ALC (Auto Level Control)

Shutter Speed : EEI

Iris : Auto iris

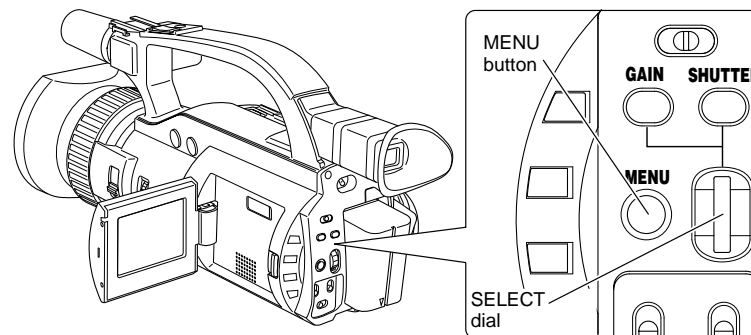

TOP MENU screen

```

--- MENU ---
MODE          MANUAL
EARPHONE LEVEL 10
SYSTEM SET...
DISPLAY SET...
CAMERA SET [CAM-A]..
▶OPERATION [CAM-A]..
CLOCK/TC...
MENU ALL RESET  CANCEL
EXIT
    
```

OPERATION menu screen

```

--- OPERATION[A] ---
▶AE          ON
IRIS        ---
SHUTTER     ---
WHITE BALANCE  PUSH AUTO
OIS         ON
CH1 AUDIO LEVEL AUTO
CH2 AUDIO LEVEL AUTO
PAGE BACK
    
```

■ Engage the recording-standby mode.

1. Press the MENU button to display the TOP MENU screen.
2. Use the SELECT dial to set the MODE item to MANUAL on the TOP MENU screen.
3. Rotate the SELECT dial to align the cursor (▶) with the OPERATION SET item on the TOP MENU screen, and then press the SELECT dial.
 - The OPERATION menu screen appears.
4. Use the SELECT dial to set the AE item on the OPERATION menu screen to ON, and then press the SELECT dial.
 - The AE function becomes ON.
5. To return to the normal screen, use either of the following methods.
 - Press the MENU button
 - or
 - Return to the TOP MENU screen and then select the EXIT item from the TOP MENU screen before pressing the SELECT dial.

• When the AE item is ON, the IRIS and SHUTTER items cannot be set. White balance and audio recording level adjustment can be selected as AUTO or MANUAL.

■ To stop use of the AE function, set the AE item to OFF on the OPERATION menu screen.

MANUAL ADJUSTMENTS Manual Focus Adjustment

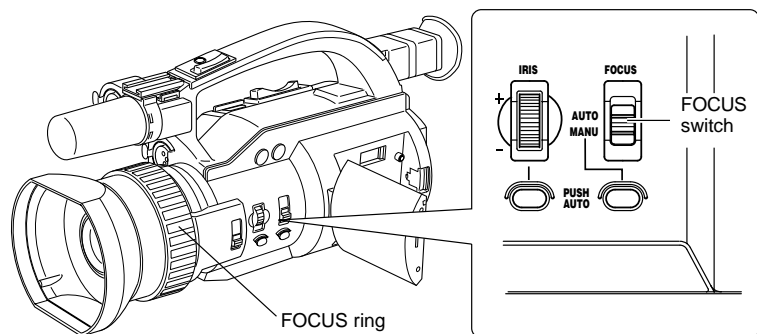

In accordance with the conditions under which the subject is recorded, adjust the focus in the manual focus mode.

In the auto focus mode, correct focus may be difficult to obtain under the following shooting conditions.

- When the subject is behind metal mesh.
- While panning quickly from a distant point to one nearby; the subject will be in focus when the panning is stopped.
- In dark places.
- When the iris is at the CLOSE end.

Operation

1. In the recording-standby mode or during shooting, set the FOCUS switch to "MANU".

The manual focus mode is engaged, and the MF indicator that indicates the manual focus mode is displayed on the LCD screen and the viewfinder screen.

2. Turn the focus ring on the lens section to adjust the focus.
 - To return to the auto focus mode, set the FOCUS switch to AUTO.

Memo:

To obtain correct focus, push the ZOOM lever to the "T" position and then adjust the focus while the subject is in the zoomed-in condition. The focus will be retained after zooming out.

If the focus is adjusted in the wide-angle condition, the subject will be out of focus when you zoom in.

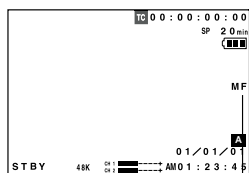

Manual focus mode indication

MANUAL ADJUSTMENTS Manual Focus Adjustment (Cont'd)

Momentarily Using Auto Focus

It is possible to momentarily use the auto focus function while in the manual focus mode.

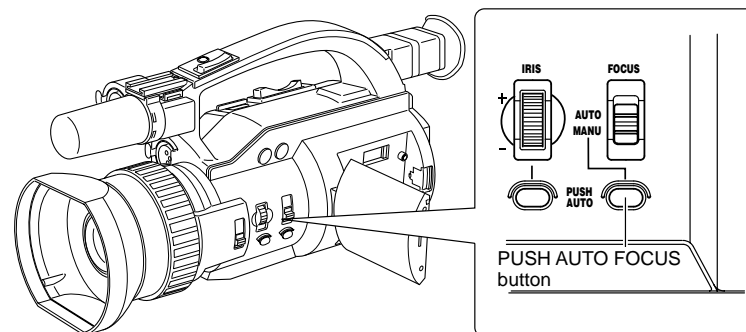

Operation

- When the FOCUS switch is set to "AUTO", the PUSH AUTO FOCUS button does not work.

1. Press the PUSH AUTO FOCUS button.
The auto focus function operates while the button remains pressed.
2. When the button is released, the mode returns to the manual focus mode.

About Auto Focus

The auto focus function automatically moves the lens back and forth to adjust the focus. The auto focus function has the following characteristics.

- It adjusts so that the vertical lines in the subject are seen as clearly as possible.
 - Focus is adjusted in accordance with parts showing most contrast.
 - Focus is only adjusted in accordance with the center portion of the image.
- Due to these characteristics, the auto function does not work well with the following types of scenes. Use manual focusing when shooting under these circumstances.
- When shooting both nearby and distant subjects at the same time.
 - When shooting through dirty glass, like windows.
 - When shooting scenes with light reflecting off the surface of the subject.
 - When shooting where the illumination is low.
 - When shooting subjects in fast motion.
 - When shooting subjects with low contrast.

MANUAL ADJUSTMENTS Using ND Filter

When the shooting conditions are too bright, the ND-filter can be used to reduce the brightness to an appropriate level. The built-in ND-filter can adjust the brightness to about 1/32 of the original.

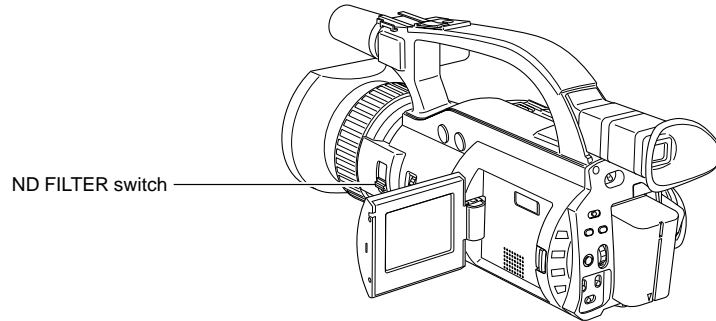

ND FILTER switch

Operation

- Please check the position of the ND FILTER switch before recording.
- Do not switch the position of the ND FILTER switch during recording. The image will be disturbed.

■ Engage the recording-standby mode.

1. Set the ND FILTER switch to "ON".
 - The built-in ND-filter is engaged, and ND filter indication appears on the LCD screen and the viewfinder screen.

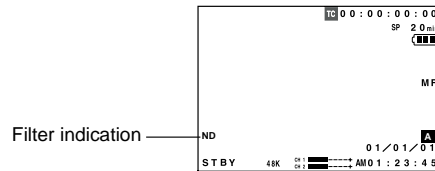

Filter indication

- **The white balance will not be adjusted correctly when using the ND-filter and shooting in the auto white balance mode.** Adjust the white balance in the manual white balance mode when using the ND-filter and shooting. (☞ See page 66.)

TENTATIVE

Obtaining Natural Tint (White Balance)

MANUAL ADJUSTMENTS

The auto white balance function of the GY-DV300 automatically makes adjustments to obtain natural tint. However, depending on the shooting conditions or the light source, sometime it may not be possible to obtain natural tint with this function. In this case, the manual white balance adjustment should be used. The result of manual white balance adjustment is stored in one of the GY-DV300's 3 types of memories. (Memory 1, 2, 3)

1. Engaging the Manual White Balance Adjustment Mode

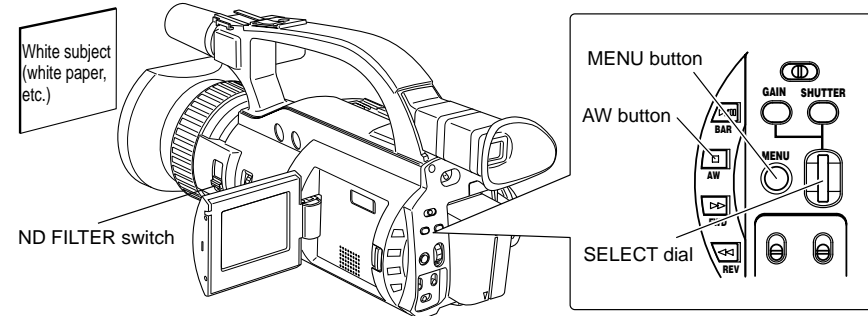

TOP MENU screen

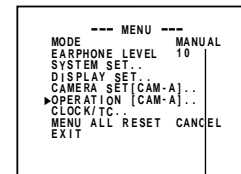

MANUAL

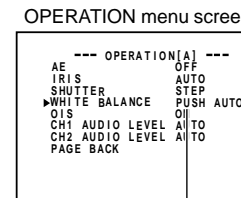

PUSH AUTO

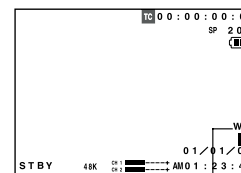

White balance setting mode

■ Engage the recording-standby mode.

1. Press the MENU button to display the TOP MENU screen.
2. Using the SELECT dial, set the MODE item on the TOP MENU screen to MANUAL.
 - The unit enters the manual shooting mode.
3. Rotate the SELECT dial to align the cursor (▶) with the OPERATION SET item on the TOP MENU screen, and then press the SELECT dial.
 - The OPERATION menu screen is displayed.
4. Using the SELECT dial, set the WHITE BALANCE item on the OPERATION menu screen to PUSH AUTO, and then press the SELECT dial.
 - The manual white balance adjustment mode is engaged.
5. To return to the normal screen, use either of the following methods.
 - Press the MENU button
 - or
 - Return to the TOP MENU screen and then select the EXIT item from the TOP MENU screen before pressing the SELECT dial.

Memo:

In the manual white balance adjustment mode, the current white balance setting mode is displayed on the LCD screen or the viewfinder screen.
 WBP: Preset mode, WB1: Memory 1 mode
 WB2: Memory 2 mode, WB3: Memory 3 mode

2. Manual White Balance Adjustment

- White balance adjustment is inhibited when PRESET is selected. The colour temperature is fixed at 3200K.
- The result of the manual white balance adjustment is stored in memory of the selected white balance mode. Even after the power has been turned off, the stored white balance condition is recalled when the relevant white balance mode is selected again.

Error indication when auto white balance adjustment is not completed normally.

An error message appears for about 3 seconds in the position indicated below.

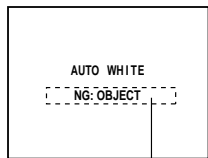

Error indication area

- **NG: OBJECT (Improper subject)**
Displayed when there is not enough white color on an object or the color temperature is not suitable. Replace the white subject or change the setting of the ND FILTER switch.
- **ERROR: LOW LIGHT (Insufficient illumination)**
Displayed when the illumination is dim.
- **ERROR: OVER LIGHT (Excessive illumination)**
Displayed when the light is excessively bright.

1. Set the ND FILTER switch in accordance with the lighting conditions.
2. Place a white object (white paper, etc.) near the centre of the screen and zoom in to fill the screen with white.
3. Select the mode in which the white balance setting should be memorized.
 - ① Press the AW button.
The current white balance setting mode is displayed for about 3 seconds, after which the condition becomes the one in which adjustment of the white balance is enabled. (PRESET, MEMORY 1, 2, 3)
 - ② Rotate the SELECT dial to select the mode for memorizing the white balance setting. (Select the mode from among the MEMORY 1, 2, and 3 options.)
When rotation of the SELECT dial stops, the selected mode is displayed for about 3 seconds.
4. Press the AW button for 1 second or more, and then release it.
 - The auto white balance adjustment is invoked.
During white balance adjustment, "AUTO WHITE OPERATION" appears on the LCD screen and the viewfinder screen.
 - When correct white balance is obtained, "AUTO WHITE OK" is displayed for about 3 seconds.

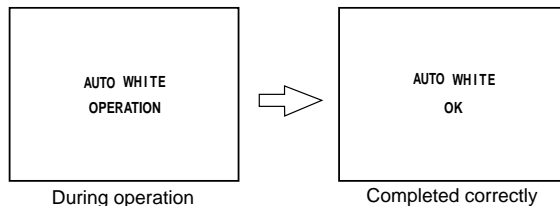

- **To return to the auto white balance adjustment mode, use either of the following methods.**
 - Set the WHITE BALANCE item to AUTO on the OPERATION menu screen
or
 - Set the MODE item to AUTO on the TOP MENU screen.
In this case the shooting mode becomes the auto mode.

MANUAL ADJUSTMENTS Manual Iris Adjustment

Adjust the iris (lens opening) manually in the following cases.

- For backlight compensation
- When the subject is too bright compared with the background
- When panning quickly from a bright place to a dark place

1. Engaging the Manual Iris Adjustment Mode

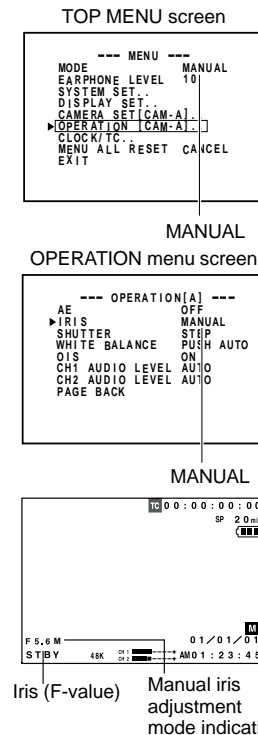
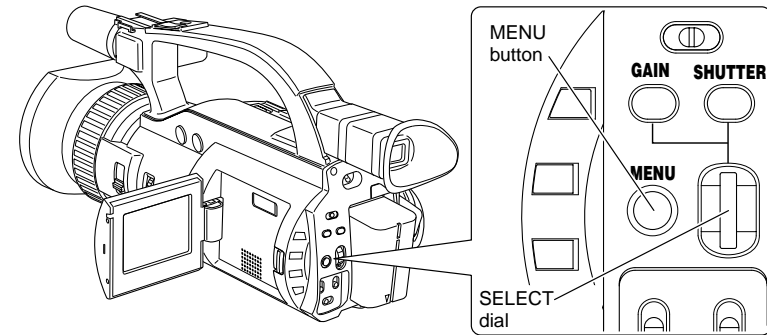

■ Engage the recording-standby mode.

1. Press the MENU button to display the TOP MENU screen.
2. Using the SELECT dial, set the MODE item on the TOP MENU screen to MANUAL.
 - The unit enters the manual shooting mode.
3. Rotate the SELECT dial to align the cursor (▶) with the OPERATION SET item on the TOP MENU screen, and then press the SELECT dial.
 - The OPERATION menu screen is displayed.
4. Using the SELECT dial, set the AE item on the OPERATION menu screen to OFF, and then press the SELECT dial.
5. Using the SELECT dial, set the IRIS item to MANUAL, and then press the SELECT dial.
6. To return to the normal screen, use either of the following methods.
 - Press the MENU button
or
 - Return to the TOP MENU screen and then select the EXIT item from the TOP MENU screen before pressing the SELECT dial.

Memo:

The iris value (F-value) and "M" are displayed on the LCD screen and the viewfinder screen in the manual iris adjustment mode.

TENTATIVE

2. Manual Iris Adjustment

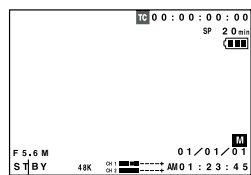
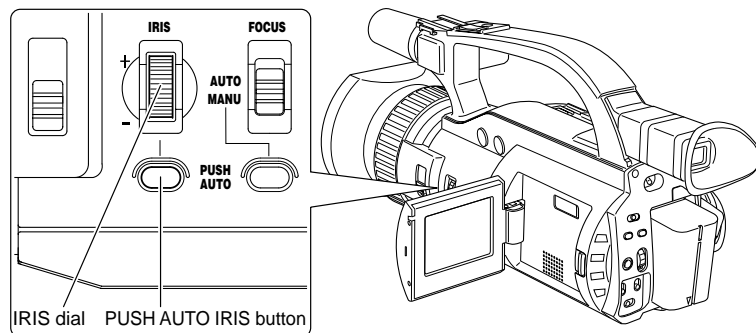

Iris value (F-value)

Adjustment in the auto iris mode

When the IRIS dial is rotated in the auto iris mode, the iris can be adjusted from +3 steps to -3 steps from the auto iris condition. When rotated upward, the iris opens. When rotated downward, the iris closes. During operation of the IRIS dial, the stop value is indicated on the LCD screen and the viewfinder screen.

F 5.6 -2

Stop value by IRIS dial in the auto iris mode.

1. Rotate the IRIS dial.

The iris value (F-value) can be adjusted from CLOSE to F1.6. Rotating the dial upward opens the iris, and rotating it downward closes the iris.

The iris value is indicated on LCD screen and the viewfinder screen.

[Setting range: F1.6, F2, F2.8, F4, F5.6, F8, F11, F16, CLOSE]

■ To return to the auto iris adjustment mode, use either of the following methods.

- Set the IRIS item to AUTO on the OPERATION menu screen
 - Set the AE item to AUTO on the OPERATION menu screen
 - Set the MODE item to AUTO on the TOP MENU screen.
- In this case the shooting mode becomes the auto mode.

Momentarily Using the Auto Iris Mode

It is possible to momentarily use the auto focus function while in the manual iris mode.

1. Press the PUSH AUTO IRIS button.

The auto iris function operates while the button remains pressed.

2. When the button is released, the mode returns to the manual iris mode.

MANUAL ADJUSTMENTS Manual Shutter Speed Adjustment

The shutter speed can be adjusted manually to obtain special effects or when shooting a fast-moving subject. The shutter speed can also be adjusted manually in the variable scanning mode rate for shooting computer monitor screens.

1. Engaging the Manual Shutter Speed Adjustment Mode (STEP/VARIABLE)

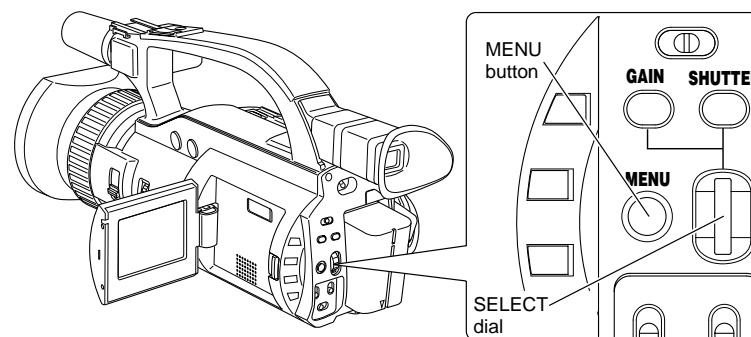

TOP MENU screen

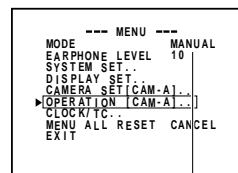

MANUAL

OPERATION menu screen

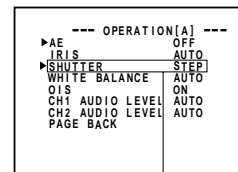

STEP or VARIABLE

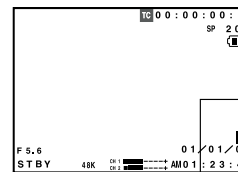

Manual shutter speed mode indicator

■ Engage the recording-standby mode.

1. Press the MENU button to display the TOP MENU screen.
2. Using the SELECT dial, set the MODE item on the TOP MENU screen to MANUAL.
 - The unit enters the manual shooting mode.
3. Rotate the SELECT dial to align the cursor (▶) with the OPERATION SET item on the TOP MENU screen, and then press the SELECT dial.
 - The OPERATION menu screen is displayed.
4. Using the SELECT dial, set the AE item on the OPERATION menu screen to OFF, and then press the SELECT dial.
5. Using the SELECT dial, set the SHUTTER item to STEP or VARIABLE, and then press the SELECT dial.
 - Select the STEP setting to change the shutter speed in fixed steps (normal manual shutter speed adjustment).
 - Select the VARIABLE setting for shooting computer screens, etc. (variable scan).
6. To return to the normal screen, use either of the following methods.
 - Press the MENU button
 - or
 - Return to the TOP MENU screen and then select the EXIT item from the TOP MENU screen before pressing the SELECT dial.

Memo:

The "S" indicator for manual shutter speed is displayed on the LCD screen and the viewfinder screen in the manual shutter speed adjustment mode. The "S" indicator is not displayed when the shutter speed is set to NORMAL (1/60 (U MODEL)/1/50 (E MODEL)).

2. Adjusting the Shutter Speed Manually

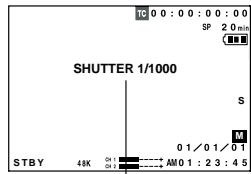
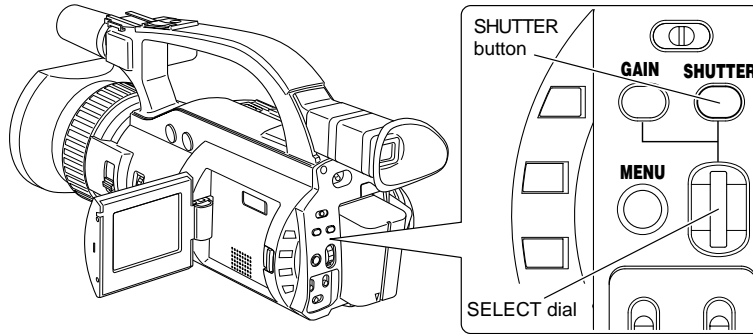

Shutter speed indication

1. Press the SHUTTER button.
 - The currently set shutter speed is shown for about 3 seconds on the LCD screen and the viewfinder screen.
 - The shutter speed can be set while the shutter speed value is displayed.
2. Rotate the SELECT dial within 3 seconds (while the shutter speed is displayed) to set the shutter speed. Rotating the dial upward increases the shutter speed, and rotating it downward lowers the speed.
3. Stop rotating the SELECT dial when the desired shutter speed is indicated. The set value is displayed for about 3 seconds before the setting is confirmed.

(U MODEL)

Setting STEP mode : NORMAL (1/60), 1/100, 1/250, 1/500,
range 1/1000, 1/2000
VARIABLE mode : 1/60.1 to 1/2084.6

(E MODEL)

Schrittmodus : NORMAL (1/50), 1/120, 1/250, 1/500,
Einstellbereich (STEP) 1/1000, 1/2000
Variabler Modus : 1/50,1 bis 2067,8
(VARIABLE)

- The set shutter value is retained in the memory even if the power is turned OFF.

■ To return to the auto shutter speed adjustment mode, use either of the following methods.

- Set the AE item to AUTO on the OPERATION menu screen
 - Set the MODE item to AUTO on the TOP MENU screen.
- In this case the shooting mode becomes the auto mode.

Shooting a Computer Display

The shutter speed should be set to variable scan mode. The variable scan mode is used to match the GY-DV300's shutter speed with the variable scan frequency of computer screens, etc. When shooting a computer screen with the camera, bright over-exposed horizontal stripes will appear in the picture if the screen's scan frequency is faster than the camera's frequency, and dark under-exposed stripes will appear if the screen's scan frequency is slower than the camera's scan frequency.

While observing the LCD screen, adjust the shutter speed until a stable image is obtained.

MANUAL ADJUSTMENTS Manual Gain Adjustment

Using the ALC (Auto Level Control) function, the GY-DV300 automatically adjusts the gain (sensitivity) in accordance with the brightness of the subject. However, if the lighting conditions are poor and where the illumination is insufficient, it is possible to adjust the gain manually.

1. Engaging the Manual Gain Adjustment Mode

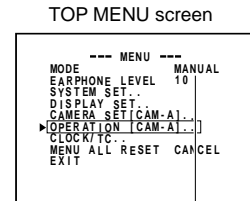
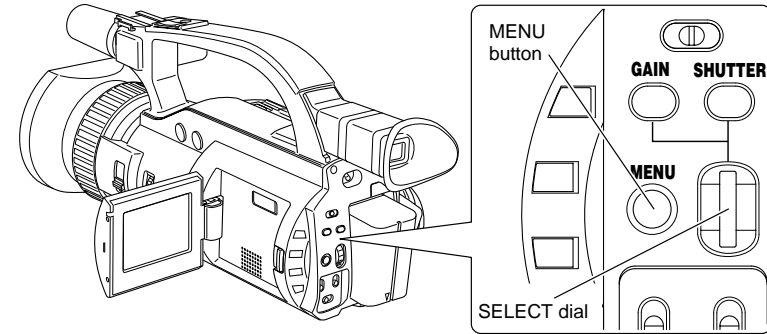

MANUAL

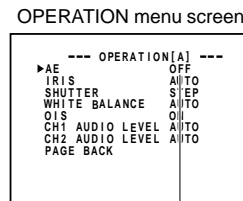

OFF

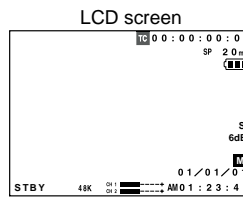

Manual gain mode indicator (L: LOLUX indicator)

■ Engage the recording-standby mode.

1. Press the MENU button to display the TOP MENU screen.
2. Using the SELECT dial, set the MODE item on the TOP MENU screen to MANUAL.
 - The unit enters the manual shooting mode.
3. Rotate the SELECT dial to align the cursor (▶) with the OPERATION SET item on the TOP MENU screen, and then press the SELECT dial.
 - The OPERATION menu screen is displayed.
4. Using the SELECT dial, set the AE item on the OPERATION menu screen to OFF, and then press the SELECT dial.
 - The manual gain adjustment mode is engaged.
5. To return to the normal screen, use either of the following methods.
 - Press the MENU button
 - or
 - Select the EXIT item from the TOP MENU screen and then press the SELECT dial.

Memo:

The set gain value is displayed on the LCD screen and the viewfinder screen in the manual gain adjustment mode. "L" is displayed in the LOLUX (low lux) mode. Nothing is displayed when the gain is set to 0 dB or AUTO.

2. Adjusting the Gain Manually

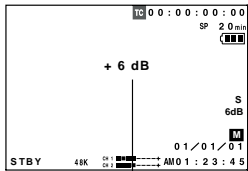
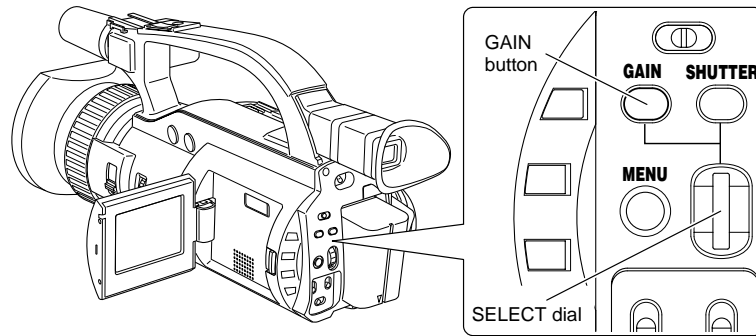

Indication of set gain value

- If the SELECT dial is pressed while the set gain value is displayed, the setting is returned to the factory setting (0 dB).
- In the auto gain adjustment mode, the GAIN button remains inoperative.

1. Press the GAIN button.
 - The currently set gain value is shown for about 3 seconds on the LCD screen and the viewfinder screen.
 - The gain value can be set while the gain value is displayed.
2. Rotate the SELECT dial within 3 seconds (while the gain value is displayed) to set the gain. Rotating the dial upward or downward increases or decreases the gain value in steps of 1 dB.
3. Stop rotating the SELECT dial when the desired gain value is indicated. The set value is displayed for about 3 seconds before the setting is confirmed.

[Setting range: -3 dB to 0 dB to +18 dB, LOLUX]

- The set gain value is retained in the memory even if the power is turned OFF.
- **To return to the auto gain adjustment mode, use either of the following methods.**
 - Set the AE item to AUTO on the OPERATION menu screen
 - Set the MODE item to AUTO on the TOP MENU screen.

In this case the shooting mode becomes the auto mode.

MANUAL ADJUSTMENTS Manual Gain Adjustment (cont'd)

3. Engaging the LOLUX Mode with the GAIN Button

In the auto or manual gain adjustment mode, the LOLUX mode can be entered directly by operating the GAIN button.

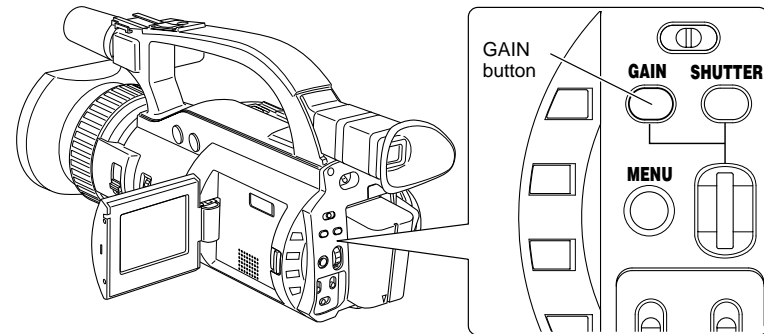

About the LOLUX mode

Used when the brightness is still insufficient when the gain is set at +18 dB.

Engaging the LOLUX mode results in an increase of +24 dB (approximately 16 times). The image definition on the screen will degrade to increase residual images, but this is due to the electrical sensitising and is not a malfunction.

Operation

1. Press the GAIN button for 1 second or more.
 - The LOLUX mode is engaged.

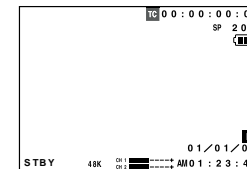

The "L" indicator for the LOLUX mode appears on the LCD screen and the viewfinder screen.

LOLUX mode indicator

2. To exit the LOLUX mode, press the GAIN button for 1 second or more.
 - The originally set gain value is restored.

Displaying Zebra Patterns

MANUAL ADJUSTMENTS for Adjustment

Zebra patterns are oblique stripes that can be displayed to indicate very bright areas of the screen. Areas where zebra patterns are indicated are likely to be blurred with white if left unadjusted. The zebra patterns can be used as a reference for manual adjustment of the brightness to adjust to the optimal level.

Zebra patterns

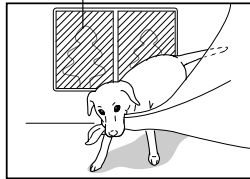

DISPLAY [1/2] menu screen

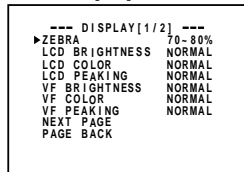

- Zebra patterns are not recorded on the tape.
- Zebra patterns are not output from the VIDEO OUT or Y/C OUT connectors.

■ Whether or not zebra patterns should be displayed, and the luminance level they should indicate, is selected by the setting of the ZEBRA item on the DISPLAY [1/2] menu screen.

1. Display the DISPLAY [1/2] menu screen.
 - ① Press the MENU button to display the TOP MENU screen.
 - ② Rotate the SELECT dial to select the DISPLAY SET item, and then press the dial to display the DISPLAY [1/2] menu screen.
2. Use the SELECT dial to select the ZEBRA item, and set the item to a value other than OFF.

Setting	Zebra Display
70 ~ 80%	Areas with a luminance level of 70% to 80%
85 ~ 95%	Areas with a luminance level of 85% to 95%
OVER 95%	Areas with a luminance level above 95%
OVER 100%	Areas with a luminance level above 100%
OFF	Not displayed

3. When you return to the normal screen, zebra patterns will appear in the appropriate areas.
4. Manually adjust iris, gain and shutter speed until the zebra patterns disappear.

Memo:

In the VTR playback mode/DV input mode (U MODEL)(when the MODE switch is set to VTR), the ZEBRA item is not shown on the DISPLAY [1/2] menu screen.

TENTATIVE

Manual Adjustment of the Audio Recording Level

MANUAL ADJUSTMENTS

The audio recording level can be manually adjusted during shooting. The audio recording level can be adjusted separately for the CH-1 and CH-2 channels.

1. Engaging the Manual Audio Recording Level Adjustment Mode

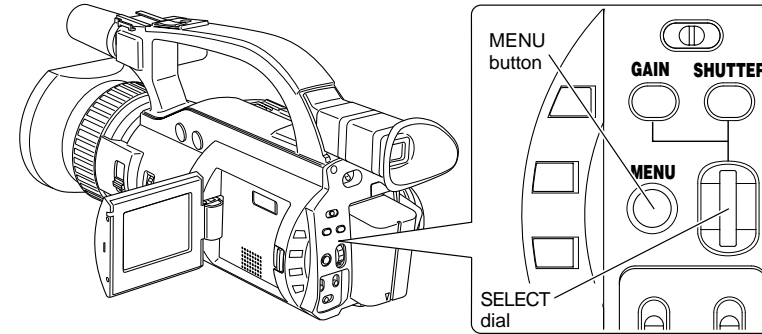

TOP MENU screen

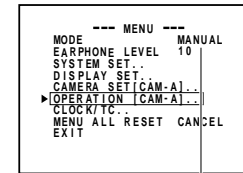

MANUAL

OPERATION menu screen

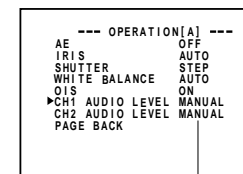

MANUAL

■ Engage the recording-standby mode.

1. Press the MENU button to display the TOP MENU screen.
2. Using the SELECT dial, set the MODE item on the TOP MENU screen to MANUAL.
 - The unit enters the manual shooting mode.
3. Rotate the SELECT dial to align the cursor (▶) with the OPERATION SET item on the TOP MENU screen, and then press the SELECT dial.
 - The OPERATION menu screen is displayed.
4. Using the SELECT dial, set the CH1 AUDIO LEVEL or CH2 AUDIO LEVEL item on the OPERATION menu screen to MANUAL, and then press the SELECT dial.
 - The manual audio recording level adjustment mode is engaged.

CH1 AUDIO LEVEL	Sets the recording level adjustment mode for CH1 channel sound to manual.
CH2 AUDIO LEVEL	Sets the recording level adjustment mode for CH2 channel sound to manual.

5. To return to the normal screen, use either of the following methods.

- Press the MENU button
- or
- Return to the TOP MENU screen and then select the EXIT item from the TOP MENU screen before pressing the SELECT dial.

2. Adjusting the Audio Recording Level Manually

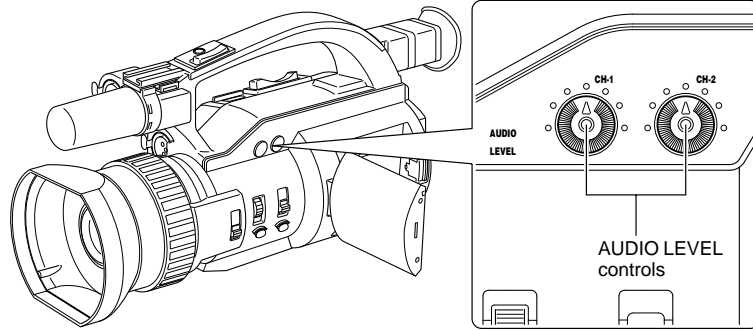

- The standard level for recording audio on the tape is -12 dB. If a tape recorded on the GY-DV300 is played back on VCR whose audio standard level is -20dB, the sound will be very loud.
- If a tape recorded on other VCR whose audio standard level is -20dB is played back on GY-DV300, the sound will be very low.

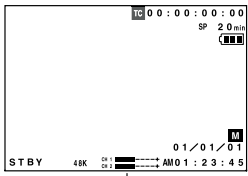

The audio level meter is displayed by setting the AUDIO LEVEL item on the DISPLAY [2/2] menu screen to ON.

1. Turn the AUDIO LEVEL controls.
 - The audio recording level of CH-1 channel is adjusted with the CH-1 AUDIO LEVEL control, and the CH-2 channel is adjusted with the CH-2 AUDIO LEVEL control. The recording level is raised when the control is turned clockwise.
- Adjust the level while observing the audio level meter on the LCD screen or the viewfinder screen and/or monitoring the sound.
 - The monitor sound is output from the EARPHONE jack (➡ See page 51)

- To return to the automatic audio recording level adjustment mode, use either of the following methods.
 - Set the CH1 AUDIO LEVEL or CH2 AUDIO LEVEL item on the OPERATION menu screen to AUTO
 - or
 - Set the MODE item to AUTO on the TOP MENU screen.
 In this case the shooting mode becomes the auto mode.

Reducing the Wind Noise of the Microphone

SYSTEM [1/2] menu screen

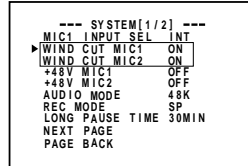

Set the WIND CUT MIC1 or WIND CUT MIC2 item on the SYSTEM [1/2] menu screen to ON.

WIND CUT MIC1	Set to ON to reduce the wind noise of the built-in microphone or a microphone connected to the MIC 1 input connector.
WIND CUT MIC2	Set to ON to reduce the wind noise of a microphone connected to the MIC 2 input connector.

Disabling Operation of the Camera-Shake Compensation Function

MANUAL ADJUSTMENTS

When shooting with the camera under conditions where the camera-shake compensation function is not required, e.g., with the camera mounted on a tripod base, etc., set the function to OFF before shooting.

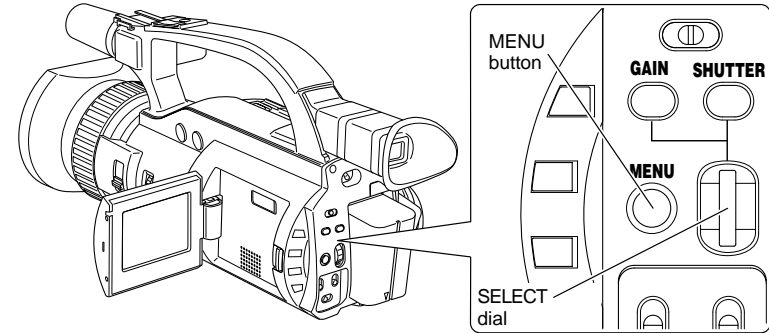

TOP MENU screen

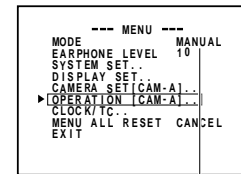

MANUAL

CAMERA menu screen

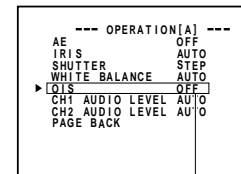

OFF

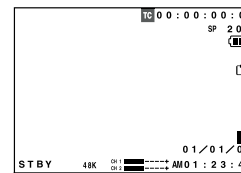

The camera-shake compensation indicator is extinguished.

OIS: Optical Image Stabilizer

- Engage the recording-standby mode.

1. Press the MENU button to display the TOP MENU screen.
2. Using the SELECT dial, set the MODE item on the TOP MENU screen to MANUAL.
 - The unit enters the manual shooting mode.
3. Rotate the SELECT dial to align the cursor (▶) with the OPERATION SET item on the TOP MENU screen, and then press the SELECT dial.
 - The OPERATION menu screen is displayed.
4. Using the SELECT dial, set the OIS item on the OPERATION menu screen to OFF, and then press the SELECT dial.
 - The camera-shake compensation function is turned OFF.
5. To return to the normal screen, use either of the following methods.
 - Press the MENU button
 - or
 - Return to the TOP MENU screen and then select the EXIT item from the TOP MENU screen before pressing the SELECT dial.

Memo:

When the camera-shake compensation function is turned OFF, the camera-shake compensation indicator is not shown on the LCD screen and the viewfinder screen.

- To turn the camera-shake compensation function ON again, use either of the following methods.
 - Set the OIS item on the OPERATION menu screen to ON
 - or
 - Set the MODE item to AUTO on the TOP MENU screen.
 In this case the shooting mode becomes the auto mode.

Adjusting the Quality of Camera Image

MANUAL ADJUSTMENTS

The GY-DV300 allows manual adjustment of the image quality of the camera image. By setting the various items on the CAMERA menu screen, you can make adjustments to obtain an image quality suiting your preference.

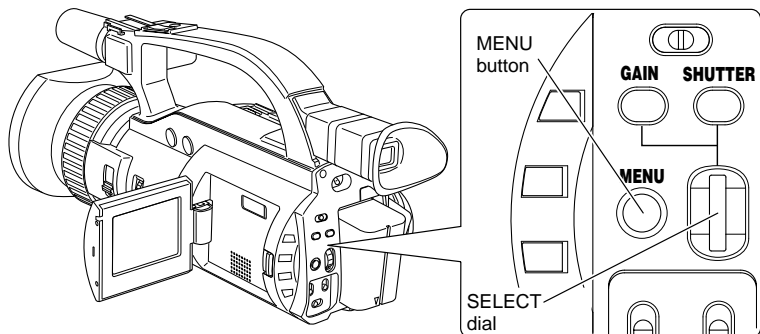

TOP MENU screen

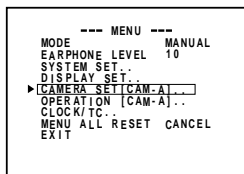

CAMERA menu screen

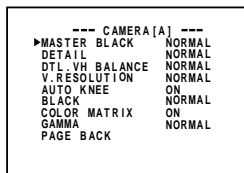

- The set values are retained in the memory even if the power is turned OFF. (Settings are saved separately for "CAM-A" and "CAM-B".)

Engage the recording-standby mode.

1. Press the MENU button to display the TOP MENU screen.
2. Rotate the SELECT dial to align the cursor (▶) with the CAMERA SET item, and then press the SELECT dial.
 - The CAMERA menu screen is displayed.
3. Make the various settings on the CAMERA menu screen.
 - ① Rotate the SELECT dial to select an item, make the setting and then press the SELECT dial to confirm and enter the setting.
 - ② Rotate the SELECT dial to change the setting of an item, and then press the SELECT dial to confirm and enter the setting.

Items for setting

- MASTER BLACK: Adjusts the pedestal level (master black)
- DETAIL: Adjusts the detail enhancement level.
- DTL. VH BALANCE: Selects the detail enhancement.
- V RESOLUTION: Selects the increase of the vertical resolution.
- AUTO KNEE: Selects the auto knee function.
- BLACK: Selects the gain for black areas.
- COLOR MATRIX: Selects the color matrix function.
- GAMMA: Selects the gamma curve.

For details on the items, see "CAMERA Menu Screen" on page 96.

4. To return to the normal screen after completing the settings, use either of the following methods.
 - Press the MENU button
 - or
 - Return to the TOP MENU screen and then select the EXIT item from the TOP MENU screen before pressing the SELECT dial.

PLAYBACK Playback of Tape

The recorded picture can be viewed on the LCD screen or in the viewfinder. The playback sound is not output from the monitoring speaker of the GY-DV300.

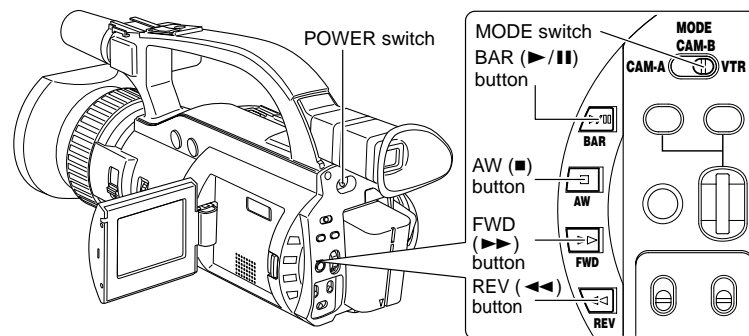

Playback Procedure

- In the VTR playback mode, no camera image is displayed on the LCD screen or the viewfinder.
- The operation mode during VTR playback is indicated on the LCD screen and the viewfinder screen.

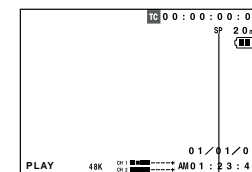

VTR operation mode indicator

Indicator showing the recording speed mode at the time of recording. (SP/LP)

1. Set the POWER switch to "ON".
2. Set the MODE switch to "VTR".
 - The GY-DV300 enters the VTR playback mode.
3. Insert the recorded videocassette.
 - The cassette tape is loaded, and the STOP mode is engaged.
4. Press the BAR (▶/||) button.
 - Playback starts.
5. Press the BAR (▶/||) button again to stop playback temporarily.
 - The unit enters the still mode (still picture shown).
6. To re-start playback, press the BAR (▶/||) button.
7. To stop playback or still mode, press the AW (■) button.
 - The unit enters the STOP mode.

Fast-Forward, Rewind (◀◀)

- Fast-forward and rewind may take longer than normally under cold conditions.
 - Press the FWD (▶▶) button in stop mode to fast forward the tape. Press the REV (◀◀) button in stop mode to rewind the tape.
 - Press the AW (■) button to stop fast forwarding or rewinding.

Search (Fast-Forward Playback/Rewind Playback)

- Video noise may be observed on the screen or the image may become unstable during the search.
 - Press the FWD (▶▶) button in the play mode or still mode to play back the tape in forward direction at high speed. Press the REV (◀◀) button to search the tape in reverse direction.
 - Press the BAR (▶/||) button to resume normal playback.
 - Press the AW (■) button to stop.

BLANK Search

Used to locate blank (unrecorded) sections on the tape, such as after the end point of a recording.

1. Enter the stop mode.
2. Press the FWD (▶▶) button and REV (◀◀) button simultaneously.
 - Blank search starts.
 - When a blank (unrecorded) section on the tape is located, the GY-DV300 enters the stop mode.
 - During blank search, "BSRH" is displayed in the section indicating the operation mode on the LCD screen or viewfinder screen.

Memo:

- When the still picture mode has continued for a specified period of time, the unit automatically switches to the tape protect mode. The time until the tape protect mode is initiated can be set to 30 minutes or 3 minutes with the LONG PAUSE TIME item on the SYSTEM [1/2] menu screen.
 - Tape protect mode: Drum rotation stops to protect the tape.
- Noise may appear in the picture during still mode.
- When the automatic tracking function is activated at the start of the playback mode, digital noise may appear in the picture.
- The GY-DV300 does not allow manual tracking adjustment.
- When playing back a tape recorded on another unit, digital noise may appear during playback.
- The data recorded on the tape for the date and time and time code can be displayed on the screen. Whether or not the data should be displayed can be selected on the DISPLAY [2/2] menu screen.

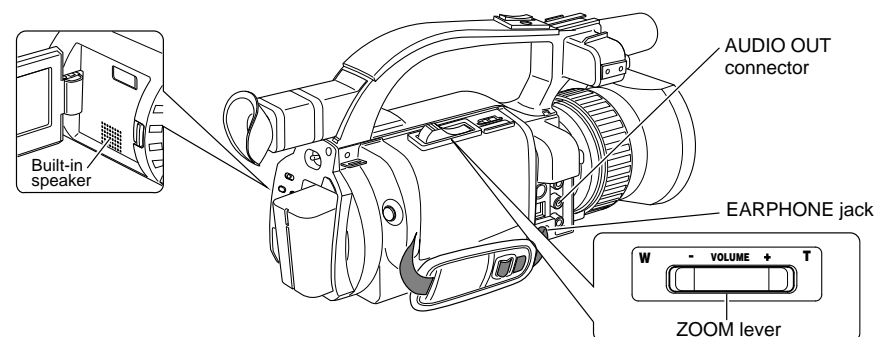
PLAYBACK Adjusting the Playback Sound Volume

Playback audio volume

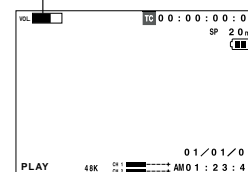

Audio level meters
(Display of these is selected on the DISPLAY [2/2] menu screen.)

- Built-in speaker
 - The audio from the built-in speaker is not output when an earphone is plugged into the EARPHONE jack.

The level of the playback sound can be controlled with the ZOOM lever on the top section of the GY-DV300.

- Pressing the lever toward the TELE (+) side raises the playback sound level, and pressing it toward the WIDE (-) side lowers it.

The playback sound is output through the built-in speaker, EARPHONE jack and AUDIO OUT connector.

- Characters indicating the playback sound volume are displayed on the LCD screen and the viewfinder screen.

PLAYBACK Outputting CH-3/CH-4 Channel Sound

4 channels are available when the DV format is recorded with 12-bit, 32 kHz audio sampling. The GY-DV300 records audio on the CH-1 and CH-2 channels. When the GY-DV300 is used for playback of tapes with sound recorded on the CH-3 and CH-4 channels on another unit, the PB AUDIO SELECT item on the VTR menu screen must be set.

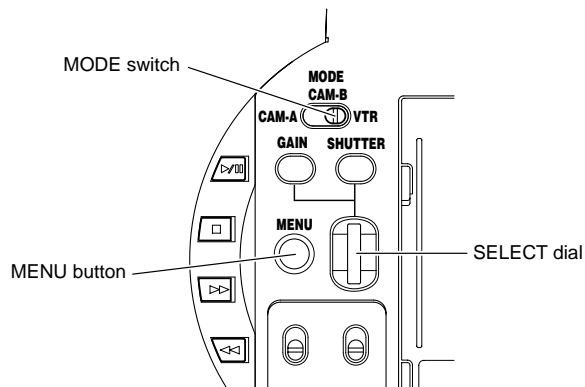

Setting

■ Confirm that the MODE switch is set to "VTR".

1. Press the MENU button to display the TOP MENU screen.
2. Using the SELECT dial, select the VTR SET item, and then press the SELECT dial.
 - The VTR menu screen is displayed.
3. Rotate the SELECT dial to align the cursor (▶) with the PB AUDIO SELECT item, and then press the SELECT dial.
 - The setting area starts blinking.
4. Rotate the SELECT dial to make the settings.

CH1/CH2 : To reproduce the sound recorded during shooting.
MIX : To simultaneously reproduce the sound recorded during shooting and the sound after-recorded on CH-3 and CH-4.
CH3/CH4 : To reproduce the sound after-recorded on CH-3 and CH-4.

5. When the SELECT dial is pressed, the set value is confirmed.
6. To return to the normal screen, use either of the following methods.
 - Press the MENU button
 - or
 - Return to the TOP MENU screen and then select the EXIT item before pressing the SELECT dial.

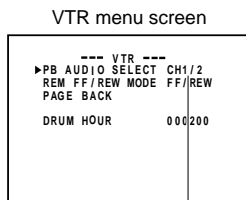

Setting

EXTERNAL COMPONENTS Connecting a Video Component with DV Connector

Connecting the GY-DV300 to another video component equipped with DV I/O connector (IEEE1394 standard) using a DV cable (optional) enables dubbing of digital signals with high picture quality and high-quality sound.

When used in a cold environment, this becomes 3 minutes regardless of the setting. (E MODEL)

Memo:

The GY-DV300 cannot be used as the recording component. (E MODEL)

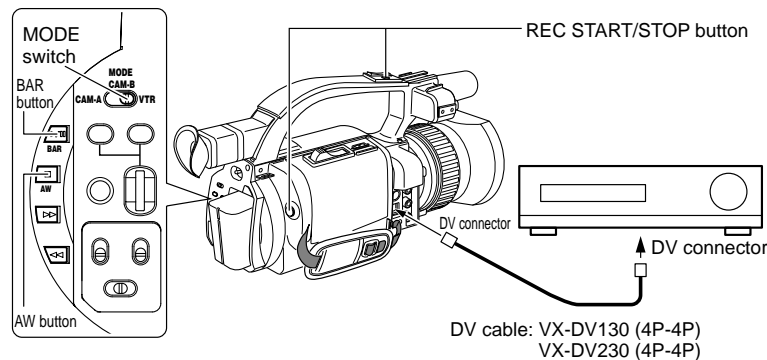

When using the GY-DV300 as playback unit (dubbing to another videocassette)

- Pressing the BAR button during playback engages the still mode.
 - When a still picture is dubbed, the dubbed picture will be coarse.
 - When the BR-DV600A's TC DUPLICATE mode is used, the time code data played back on the GY-DV300 can also be dubbed.
1. Connect the units with the DV cable.
 2. Turn ON both units.
 3. Set the MODE switch on the GY-DV300 to "VTR".
 4. Insert the videocassettes.
 - GY-DV300: Insert the recorded videocassette.
 - Recording unit: Insert the videocassette to be dubbed to.
 5. Press the BAR button on the GY-DV300 to start playback.
 6. Start recording on the recording unit.
 - For details, see the instructions to the unit used for recording.
 7. When dubbing is completed.
 - Stop recording on the recording unit, and then press the AW button on the GY-DV300 to stop playback.

Memo:

- The operation methods differ with the characteristics and specifications of the connected equipment. Even if connection is possible, operation or data communication may sometimes be impossible to perform.
- When a D-9 (digital S) component is connected by means of IEEE1394, (data and time data is not output from the D-9 component. (U MODEL) Also, data and time data is not recorded on the D-9 component.
- If noise appears on the screen or the sound drops out, disconnect the DV cable and then connect it again or turn off the GY-DV300 before turning it on again.

TENTATIVE

When using the GY-DV300 as recording unit (dubbing from another videocassette) (E MODEL)

Date and time data: Data sent from the playback unit is recorded
Time code: The data generated by the GY-DV300's time code generator (☞ See page 42.)

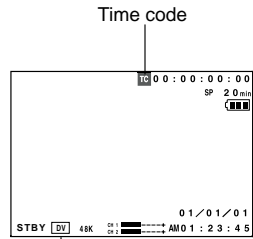

DV input signal indicator

- The GY-DV300 is provided with two REC START/STOP buttons: one on the rear section of the unit, and one on top of the handle. Both can be used for the operation.

1. Connect the units with the DV cable.
2. Turn ON both units.
3. Set the MODE switch on the GY-DV300 to "VTR".
4. Insert the videocassettes.
GY-DV300 : Insert the videocassette to be dubbed to.
Player unit : Insert the recorded videocassette.
5. Start playback on the playback unit.
 For details, see the instructions to the unit used for playback.
 - The playback picture from the playback unit appears on the GY-DV300's LCD screen and viewfinder screen.
 - The DV input signal indicator (DV) is shown on the screens.
6. Press the REC START/STOP button on the GY-DV300 to start recording.
 - To temporarily pause the recording, press the REC START/STOP button.
 - To restart the recording, press the REC START/STOP button again.
7. When dubbing is completed.
 Press the REC START/STOP button or the AW (■) button on the GY-DV300 to stop recording, and then stop playback on the playback unit.

Recording the GY-DV300 Camera Image for Backup Through the DV Connector

To use the GY-DV300 as camera and record a backup picture on another video component through the DV connector, set the MODE switch to "CAM-A" or "CAM-B".

Memo:

When using the BR-DV600UA's back-up recording function, backup can be set to start automatically in accordance with the status of remaining tape on the GY-DV300.

MENU SCREEN MENU Screen Structure (Shooting Mode)

The MENU consists of multiple layers of menu screens. The following shows the MENU screen structure when the MODE switch on the rear section is set to "CAM-A" or "CAM-B". Separate menu screens are displayed for each position of the MODE switch ("CAM-A" or "CAM-B" position). The current position of the MODE switch (e.g., "CAM-A" or "CAM-B") is indicated after the CAMERA SET and OPERATION SET items on the TOP MENU screen.

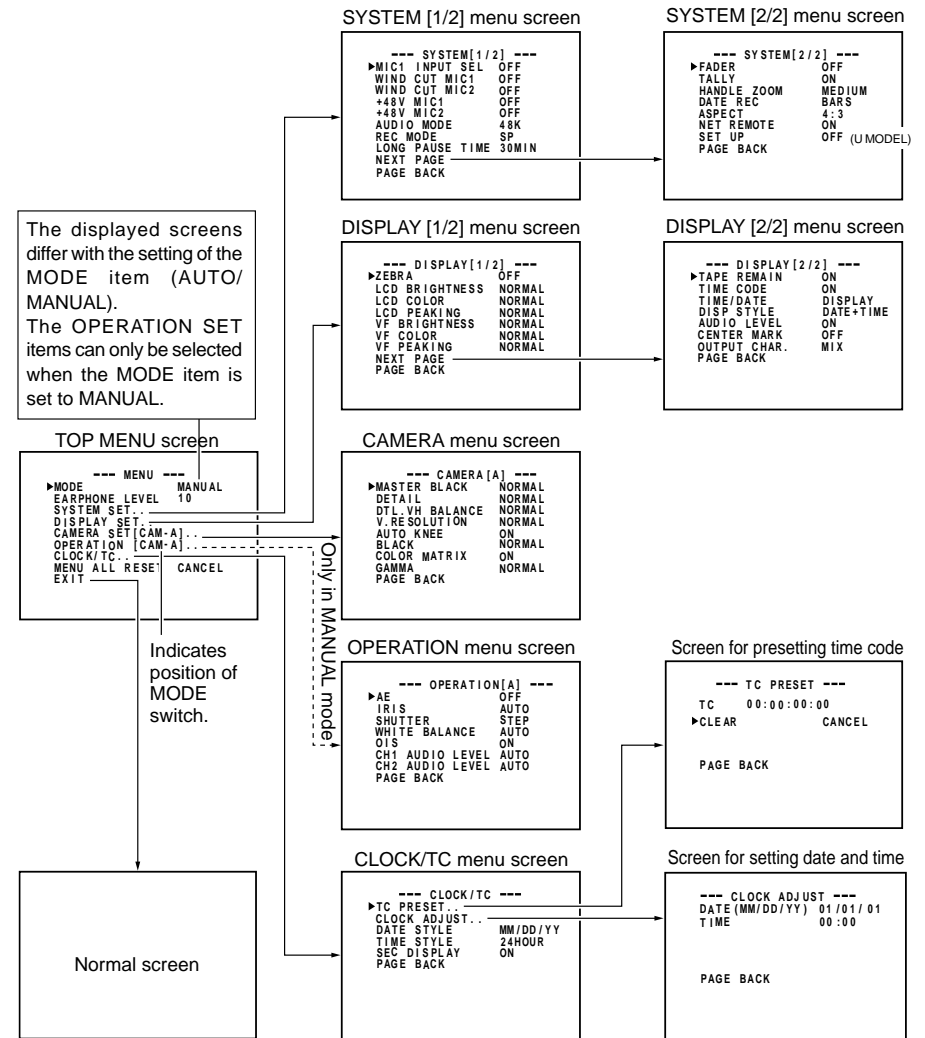

MENU SCREEN Structure (VTR Playback/DV Signal Input (U MODEL) Mode)

The following shows the MENU screen structure when the MODE switch on the rear section is set to "VTR".

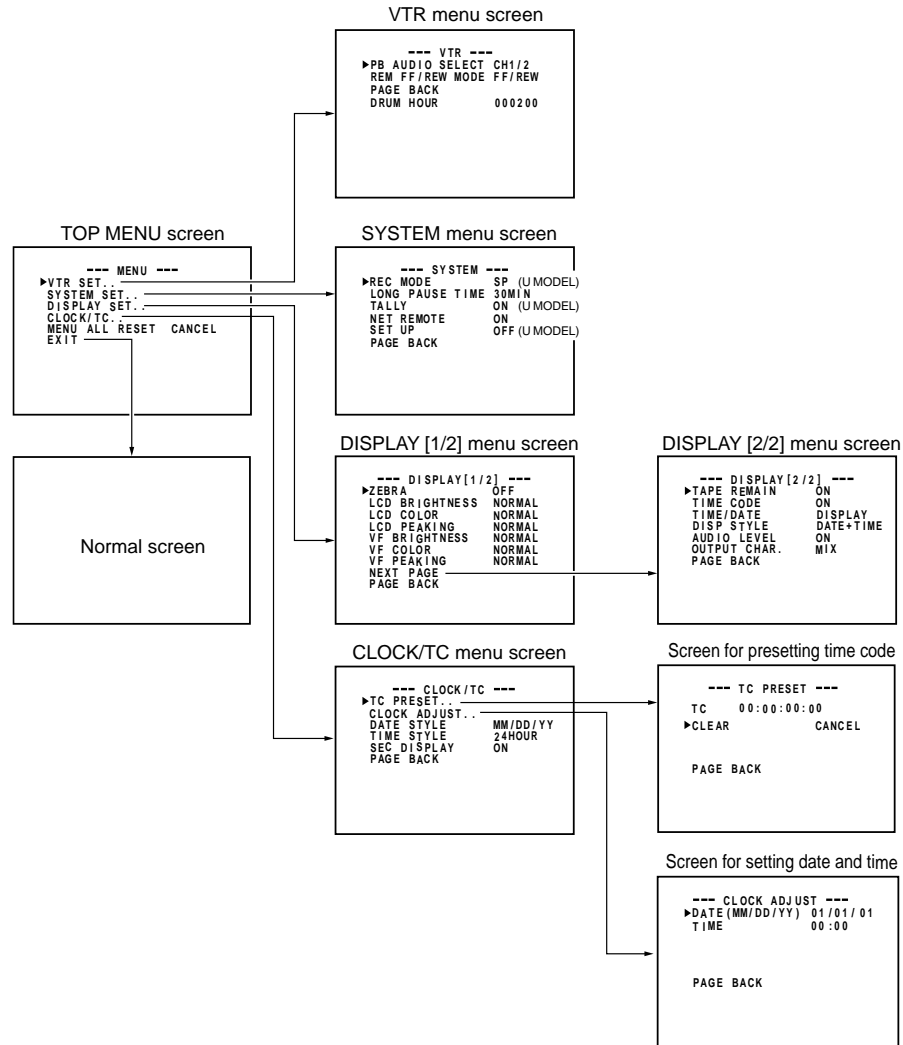

MENU SCREEN Setting Menu Screens

Various settings are made on the menu screens in accordance with the mode of usage of the GY-DV300. In the shooting mode, settings can be made on two separate sets of menus in accordance with the setting of the MODE switch ("CAM-A" or "CAM-B"). The contents of settings are retained in the GY-DV300's memory also when the power is turned off.

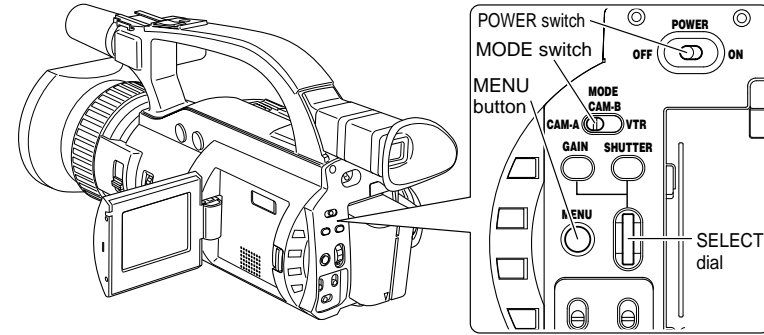

- Menu cannot be set during a recording.
- Make the settings while observing the LCD screen or the viewfinder screen. If the OUTPUT CHAR. item on the DISPLAY [2/2] screen is set to MIX, the menu screen can also be viewed on a monitor connected to the VIDEO OUT or Y/C OUT connector.

In the shooting mode, the MODE item on the TOP MENU screen is used to decide whether the AUTO mode or MANUAL mode should be used.

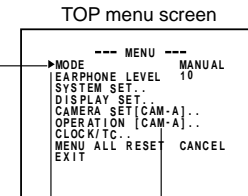

Cursor
Indicates position of MODE switch

1. Set the POWER switch to "ON".
2. Set the MODE switch. ("CAM-A", "CAM-B", "VTR")
3. Press the MENU button for about 1 second.
 - The TOP MENU screen appears.
4. Select the menu screen to be set. Rotate the SELECT dial to align the cursor (▶) with the menu screen to be set, and then press the SELECT dial.
 - The selected menu screen appears.
5. Select the menu item on the menu screen. Rotate the SELECT dial to align the cursor (▶) with the menu item to be set, and then press the SELECT dial.
 - The setting area of the selected item starts blinking, and the desired value can now be set.

TENTATIVE

SYSTEM [1/2] menu screen

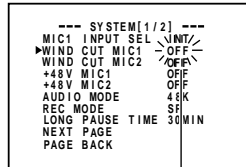

Set value

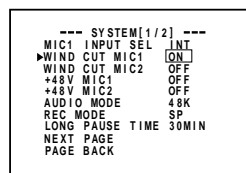

TOP menu screen

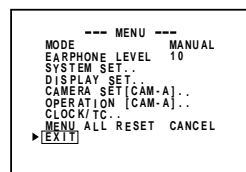

6. Changing the set value.
 Rotate the SELECT dial to change the setting, and then press the SELECT dial.
 - The set value stops blinking and the setting is entered.
7. Return to the TOP MENU.
 Rotate the SELECT dial to align the cursor (▶) with the PAGE BACK item, and then press the SELECT dial.
 - To change multiple items, repeat the procedures in steps 5 and 6 above.
8. To return to the normal screen after completing the settings, use either of the following methods.
 - Press the MENU button
 - or
 - Return to the TOP MENU screen and align the cursor (▶) with the EXIT item, and then press the SELECT dial.

MENU SCREEN Contents of Menu Screens

Different menu screens are displayed depending on whether the GY-DV300 is in the shooting mode or in the VTR playback mode.

The setting values marked with the ● symbol in the explanations of the menu screens are the factory settings.

TOP MENU Screen (Shooting Mode)

Item	Set Value	Contents
MODE	●AUTO MANUAL	Selects the shooting mode. AUTO : Auto shooting mode. MANUAL: Manual shooting mode. Adjustment items can be set separately on the OPERATION menu screen.
EARPHONE LEVEL	MIN 1 } ● 10 } 20 MAX	Sets the volume of the sound from the EARPHONE jack in the shooting mode. A higher value makes the sound louder.
SYSTEM SET		Displays a menu screen related to the various functions available in the shooting mode.
DISPLAY SET		Displays a menu screen related to the display and brightness of the LCD screen and viewfinder screen.
CAMERA SET		Displays a menu screen related to adjustment of the image quality of the camera image.
OPERATION		Displays a menu screen for individual setting of AUTO/MANUAL adjustment items in the shooting mode. This is only valid when the MODE item is set to MANUAL.
CLOCK/TC		Displays a menu screen for setting the date and time and the time code.
MENU ALL RESET	●CANCEL EXECUTE	To select whether the settings on menu screens should be reset to the factory settings. When the reset operation is performed, the menu settings for the CAM-A, CAM-B and VTR playback modes are all reset to the factory settings. CANCEL : Not reset EXECUTE : Reset When the reset operation is performed, the power is automatically turned ON again after it has been turned OFF.
EXIT		The normal screen returns when the SELECT dial is pressed while the cursor is aligned with this item.

TOP MENU Screen (VTR Playback/DV Signal Input Mode)

Item	Set Value	Contents
VTR SET		Displays a menu screen related VTR playback.
SYSTEM SET		Displays a menu screen related to the various functions.
DISPLAY SET		Displays a menu screen related to the display and brightness of the LCD screen and viewfinder screen.
CLOCK/TC		Displays a menu screen for setting the date and time and the time code.
MENU ALL RESET	●CANCEL EXECUTE	To select whether the settings on menu screens should be reset to the factory settings. When the reset operation is performed, the menu settings for the CAM-A, CAM-B and VTR playback modes are all reset to the factory settings. CANCEL : Not reset EXECUTE : Reset When the reset operation is performed, the power is automatically turned ON again after it has been turned OFF.
EXIT		The normal screen returns when the SELECT dial is pressed while the cursor is aligned with this item.

MENU SCREEN Contents of Menu Screens (cont'd)

The displayed menu screens of the SYSTEM Menu Screen differ with the shooting mode and the VTR mode.

SYSTEM Menu Screen (Shooting mode)

In the shooting mode, the SYSTEM Menu Screen consists of two screens (1/2 screen and 2/2 screen).

■ SYSTEM 1/2 screen

Item	Set Value	Contents
MIC1 INPUT SEL	● INT XLR	Selects whether the built-in microphone or a microphone connected to the MIC 1 input connector should be used. INT : Use this setting when the built-in microphone should be used. XLR : Use this setting when a microphone connected to the MIC 1 input connector should be used.
WIND CUT MIC1	● OFF ON	Selects whether or not the wind noise picked up by the internal microphone or a microphone connected to the MIC 1 input connector is reduced. OFF : Not reduced. ON : Reduced.
WIND CUT MIC2	● OFF ON	Selects whether or not the wind noise picked up by a microphone connected to the MIC 2 input connector is reduced. OFF : Not reduced. ON : Reduced.
+48V MIC1	● OFF ON	To set whether +48 V power should be supplied to a microphone connected to the MIC 1 or MIC 2 input connector. MIC 1 and MIC 2 are set separately.
+48V MIC2	● OFF ON	OFF : +48 V power is not supplied. ON : +48 V power is supplied. Use this setting when a phantom microphone is used. Memo: “- - -” is displayed when the MIC1 INPUT SEL item is set to INT, and setting is not possible.
AUDIO MODE	32K ● 48K	Selects the sampling frequency for audio recording (common for CH-1 and CH-2) 32K : Recording is performed with 12-bit, 32 kHz sampling frequency 48K : Recording is performed with 16-bit, 48 kHz sampling frequency * 4 channels are available when the DV format is recorded with 12-bit, 32 kHz audio sampling. The GY-DV300 records audio on the CH-1 and CH-2 channels. The GY-DV300 does not allow after-recording.
REC MODE	● SP LP	Selects the recording speed mode. SP : Standard Play recording speed mode. LP : Long Play recording speed mode (recording time is 1.5 times longer than in the SP mode.)

SYSTEM Menu Screens (Shooting mode) (Cont'd)

Item	Set Value	Contents
LONG PAUSE TIME	3 MIN ● 30 MIN	Selects the time (minutes) before the tape protection mode is engaged when the recording-standby mode or still mode continues. Tape protection mode: Drum rotation stops automatically. When used in a cold environment, this becomes 3 minutes regardless of the setting. 3 MIN : 3 minutes 30 MIN : 30 minutes When used in a cold environment, this becomes 3 minutes regardless of the setting.
NEXT PAGE		The SYSTEM [2/2] menu screen appears when the SELECT dial is pressed.
PAGE BACK		The TOP MENU returns when the SELECT dial is pressed.

■ SYSTEM [2/2] Menu Screen

Item	Set Value	Contents
FADER	● OFF BLACK	Selects whether fade is performed when recording is started and stopped. OFF : No fade. BLACK : Picture fades in from black screen when recording is started; fades out to black screen when recording is stopped.
TALLY	OFF ● ON	Selects whether or not the TALLY lamp lights during recording. OFF : TALLY lamp does not light during recording. ON : TALLY lamp lights during recording
HANDLE ZOOM	SLOW ● MEDIUM FAST	Sets the zoom speed for when the ZOOM lever on the handle section is used. SLOW : Zoom operation is slow MEDIUM : Normal zoom operation speed FAST : Zoom operation is fast
DATE REC	● BARS BARS+CAM	Selects the mode for recording the date and time on the tape. When the date and time should be recorded on the tape, the TIME/DATE item must be set to DISP+REC on the DISPLAY [2/2] menu screen. Select the style of the time and date with the DISP STYLE item on the DISPLAY [2/2] menu screen. BARS : Recorded when built-in color bar signal is output. BARS+CAM : Recorded when built-in color bar signal and the camera image are output.
ASPECT	● 4:3 LETTER	Selects the image size of the recorded image. 4:3 : To record with the normal screen size with an aspect ratio of 4:3. LETTER : To record with a LETTER BOX screen with an aspect ratio of 16:9 where the upper and lower part of the image is cut off.

SYSTEM Menu Screens (Shooting mode) (Cont'd)

Item	Set Value	Contents
NET REMOTE	OFF ● ON	Used when the optional network pack KA-DV300 is mounted. Selects whether the GY-DV300 should be controlled by external signals. OFF : Not controlled. ON : Controlled
SET UP (U MODEL)	OFF ● ON	Selects whether the composite video or Y/C separate signal should be provided with the setup level at the time of recording. OFF : Setup level not provided. ON : Setup level provided. (Level 7.5%)
PAGE BACK		The SYSTEM [1/2] menu screen returns when the SELECT dial is pressed.

SYSTEM Menu Screens (VTR Playback mode)

Item	Set Value	Contents
REC MODE (U MODEL)	● SP LP	Selects the recording speed mode when recording DV signals. SP: Standard recording speed LP: Long time recording speed mode (allows 1.5 times longer recording than in the SP mode on the same amount of tape.)
LONG PAUSE TIME	3 MIN ● 30 MIN	Selects the time (minutes) before the tape protection mode is engaged when the recording-standby mode or still mode continues. Tape protection mode: Drum rotation stops automatically. 3 MIN : 3 minutes 30 MIN : 30 minutes When used in a cold environment, this becomes 3 minutes regardless of the setting.
TALLY (U MODEL)	OFF ● ON	Selects whether or not the TALLY lamp should light when recording DV signals. OFF : The TALLY lamp does not light. ON : The TALLY lamp lights.
NET REMOTE	OFF ● ON	Used when the optional network pack KA-DV300 is mounted. Selects when the GY-DV300 should be controlled by external signals. OFF : Not controlled. ON : Controlled
SET UP (U MODEL)	OFF ● ON	Selects whether the composite video or Y/C separate signal should be provided with the setup level at the time of playback. OFF : Setup level not provided. ON : Setup level provided. (Level 7.5%)
PAGE BACK		The TOP MENU returns when the SELECT dial is pressed.

MENU SCREEN Contents of Menu Screens (cont'd)

DISPLAY Menu Screen

The DISPLAY Menu Screen consists of two screens (1/2 Screen and 2/2 Screen).

■ DISPLAY [1/2] Menu Screen

Item	Set Value	Contents
ZEBRA	● OFF 70 – 80% 85 – 95% OVER 95% OVER 100%	Selects whether zebra patterns should be shown on the LCD screen and the viewfinder screen, and sets the luminance level of the subject areas where the zebra pattern is displayed OFF: Not displayed. 70 – 80% : Zebra pattern displayed in areas with a luminance level of 70% to 80%. 85 – 95% : Zebra pattern displayed in areas with a luminance level of 85% to 95%. OVER 95% : Zebra pattern displayed in areas with a luminance level above 95%. OVER 100% : Zebra pattern displayed in areas with a luminance level above 100%. Memo: When the MODE switch is set to VTR (VTR playback /DV input mode), this item is not displayed.
LCD BRIGHTNESS	MAX 4 }	Adjusts the brightness of the LCD screen. To brighten ... Make value higher To dim ... Make value lower
LCD COLOR	1 ● NORMAL -1 }	Adjusts the color saturation of the LCD screen. Higher color saturation Make value higher Lower color saturation Make value lower
LCD PEAKING	-4 MIN	Adjusts the contrast of the LCD screen. To make contours sharper ... Make value higher To soften contours ... Make value lower
VF BRIGHTNESS		Adjusts the brightness of the viewfinder screen. To brighten Make value higher To dim Make value lower
VF COLOR		Adjusts the color saturation of the viewfinder screen. Higher color saturation Make value higher Lower color saturation Make value lower
VF PEAKING		Adjusts the contrast of the viewfinder screen. To make contours sharper Make value higher To soften contours Make value lower
NEXT PAGE		The DISPLAY [2/2] menu screen returns when the SELECT dial is pressed. (Menu screen for selecting display items)
PAGE BACK		The TOP MENU returns when the SELECT dial is pressed.

DISPLAY Menu Screen (cont'd)

■ DISPLAY [2/2] Menu Screen

Item	Set Value	Contents
TAPE REMAIN	●ON OFF	Selects whether the remaining tape time indication should be shown on the LCD screen and the viewfinder screen. ON : Displayed OFF : Not displayed
TIME CODE	●ON OFF	Selects whether the time code should be shown on the LCD screen and the viewfinder screen. ON : Displayed OFF : Not displayed
TIME/DATE	DISP+REC ●DISPLAY OFF	Selects whether the date and time should be shown on the LCD screen or the viewfinder screen, and whether the indications should be recorded on the tape. DISP+REC : Displayed on the LCD screen or the viewfinder screen and recorded on the tape. DISPLAY : Only displayed on the LCD screen or the viewfinder screen. OFF : Neither displayed nor recorded. The conditions for recording the date and time are selected with the DATE REC item on the SYSTEM [2/2] menu screen.
<div style="border: 1px solid black; padding: 5px;"> When the mode switch is set to VTR, DISP + REC changes into OFF (D+R). In this case, TIME/DATE is neither displayed nor recorded. </div>		
DISP STYLE	●DATE+TIME TIME DATE	Selects the style of the date and time indication and whether this should be shown on the LCD screen and the viewfinder screen. DATE+TIME : Date and time are shown. TIME : Time is shown. DATE : Date is shown.
AUDIO LEVEL	●ON OFF	Selects whether the audio level meters should be shown on the LCD screen and the viewfinder screen. ON : Displayed OFF : Not displayed
CENTER MARK	●OFF ON	Sets whether or not a centre mark is displayed. ON : Displayed OFF : Not displayed <div style="border: 1px solid black; padding: 5px;"> Memo: When the MODE switch is set to VTR (VTR playback /DV input mode), this item is not displayed. </div>
OUTPUT CHAR.	OFF ●MIX	Selects whether on-screen-indications are displayed on a monitor connected to the VIDEO OUT or Y/C OUT connector. OFF : On-screen-indications are not displayed MIX : On-screen-indications are displayed
PAGE BACK		The DISPLAY [1/2] menu screen returns when the SELECT dial is pressed.

MENU SCREEN Contents of Menu Screens (cont'd)

CAMERA Menu Screen

The CAMERA menu screen can only be set in the shooting mode.

The position ("CAM A" or "CAM B") of the MODE switch is indicated after the menu title name.

Item	Set Value	Contents
MASTER BLACK	MAX 9 } 1 ●NORMAL	Adjusts the pedestal level (master black) which is the reference of black. To increase the pedestal level... Make value higher To decrease the pedestal level... Make value lower
DETAIL	-1 } -9 MIN	Adjusts the contour (detail) enhancement level. To sharpen contours Make value higher To soften contours Make value lower
DTL. VH FREQUENCY	MAX 4 } 1 ●NORMAL -1 } -4 MIN	Sets the direction, horizontal (H) or vertical (V), in which detail enhancement is applied more strongly. To apply stronger enhancement in H direction: Make value higher To apply stronger enhancement in V direction: Make value smaller
V. RESOLUTION	●NORMAL V.MAX	Selects the increase of the vertical resolution. NORMAL: Standard vertical resolution (380 lines). V.MAX: Increased vertical resolution (420 lines) However, the sensitivity is degraded and the bright sections may be colored depending on the subject.
AUTO KNEE	OFF ●ON	To select whether the auto knee function should operate. OFF: Does not operate. ON: Operates. <hr/> AUTO KNEE function When shooting a foreground subject, such as a human being, etc., with a high-brightness background, if the brightness level is set for the foreground subject, the background image will be blurred with white. In such a case, a clearer background is obtained when the auto knee function is used. This function is effective especially in the following cases: <ul style="list-style-type: none"> ● When shooting a human being indoors with a view to the landscape out through a window. ● When shooting a human being in the shade on a fine day. ● When shooting a high-contrast scene. * If a fast-moving high-brightness section like a car in sunlight is shot, the auto knee function may change the brightness of the entire image along with the motion of the object. In this case, set the auto knee function to OFF.

CAMERA Menu Screen (Cont'd)

Item	Set Value	Contents
BLACK	●NORMAL ●STRETCH ●COMPRESS	Selects the gain for the dark section of the image. Set to an appropriate position in accordance with the subject. NORMAL : Standard mode. STRETCH : By stretching the signal only for the dark section, contrast in the dark portion of the image is enhanced. COMPRESS : When an entire image is relatively light and the contrast is low, the gain of the dark section is compressed to increase the contrast.
COLOR MATRIX	●ON ○OFF	Sets the color matrix. ON: The color reproducibility is enhanced, but noise increases. OFF: The function is off. Memo: When the GAMMA item is set to CINEMA, the “— —” indication will be shown for the COLOR MATRIX item and the item cannot be set.
GAMMA	●NORMAL ●CINEMA	Selects the gamma curve which determines the reproduction of black. NORMAL : Standard condition. Normally, this setting is used. CINEMA : Cinema mode. This setting is used to obtain a gamma curve similar to that of cinema movies.
PAGE BACK		The TOP MENU returns when the SELECT dial is pressed.

MENU SCREEN Contents of Menu Screens (cont'd)

OPERATION Menu Screen

The OPERATION menu screen can only be set in the manual shooting mode.
The position (“CAM A” or “CAM B”) of the MODE switch is indicated after the menu title name.
The item values set off by the ● symbol are the factory settings when the MODE switch is set to CAM-A.
The item values set off by the ○ symbol are the factory settings when the MODE switch is set to CAM-B.

Item	Set Value	Contents
AE	●ON ○OFF	Sets the AE (automatic exposure) function to ON or OFF. ON : AE function operates. Gain is set to ALC, shutter to EEI, and iris is set to auto iris. OFF: AE function does not operate. ● When ON, “—” is displayed for the following IRIS and SHUTTER items that cannot be set in this condition.
IRIS	●AUTO ○MANUAL	Selects automatic or manual iris adjustment. Enabled when the AE item is OFF. AUTO : Selects the auto mode. MANUAL : Selects the manual mode.
SHUTTER	●STEP ○VARIABLE	Selects whether fixed shutter speed (STEP) or variable scanning rate should be employed for manual shutter speed adjustment. Enabled when the AE item is OFF. STEP : Enables setting of different fixed shutter speeds. (1/100, 1/250, 1/500, 1/1000, 1/2000) VARIABLE : For changing the shutter speed at variable scanning rate. Selected when shooting computer monitor screens, etc. (60.1 Hz to 2084.6 Hz)
WHITE BALANCE	●AUTO ○PUSH AUTO	Selects automatic or manual white balance adjustment. AUTO : Selects the auto mode. PUSH AUTO : Selects the manual mode.
OIS	○OFF ●ON	Selects whether or not camera-shake compensation should operate. OFF: Not operating. ON : Operating.
CH1 AUDIO LEVEL	●AUTO ○MANUAL	Selects whether the recording level adjustment of the CH1 channel sound is performed automatically or manually. AUTO : Selects the auto mode. MANUAL : Selects the manual mode.
CH2 AUDIO LEVEL	●AUTO ○MANUAL	Selects whether the recording level adjustment of the CH2 channel sound is performed automatically or manually. AUTO : Selects the auto mode. MANUAL : Selects the manual mode.
PAGE BACK		The TOP MENU returns when the SELECT dial is pressed.

CLOCK/TC Menu Screen

Item	Set Value	Contents
TC PRESET		The screen for setting the time code appears when the SELECT dial is pressed. (☞ See page 45.)
CLOCK ADJUST		The screen for setting the date and time appears when the SELECT dial is pressed. (☞ See page 41.)
DATE STYLE	YY/MM/DD ● MM/DD/YY DD/MM/YY	For selecting the style of the date display. YY/MM/DD: Year/Month/Date display style. MM/DD/YY: Month/Date/Year display style. DD/MM/YY: Date/Month/Year display style.
TIME STYLE	● 24 HOUR 12 HOUR	For selecting the style of the time display. 24 HOUR : Displays the time using the 24-hour system. 12 HOUR : Displays the time using the 12-hour system.
SEC DISPLAY	● ON OFF	For selecting whether to include the seconds in the time display. ON : Seconds are displayed. OFF : Seconds are not displayed.
PAGE BACK		The TOP MENU returns when the SELECT dial is pressed.

VTR Menu Screen

The VTR menu screen can only be set in the VTR playback mode.

Item	Set Value	Contents
PB AUDIO SELECT	● CH1/2 MIX CH3/4	Used to select which channels to reproduce when playing back a tape with sound recorded on 4 channels. CH1/2 : To reproduce the sound recorded on CH-1 and CH-2. The GY-DV300 records audio on the CH-1 and CH-2 channels during shooting. MIX : To simultaneously reproduce the sound of all four channels. CH3/4 : To reproduce the sound of the CH-3 and CH-4 channels. Memo: The GY-DV300 does not allow after-recording on the CH-3 and CH-4 channels.
REM FF/REW MODE	● FF/REW SEARCH	This selects the operation when the FF or REW command is received when the GY-DV300 is controlled by the Non-liner editing controller FF/REW : Fast forward or rewind operation. Normally, use this setting. SEARCH: FWD search or REV search operation. Use this setting if Cue up operation is not performed correctly when this item is set to FF/REW.
PAGE BACK		The TOP MENU (VTR) returns when the SELECT dial is pressed.
DRUM HOUR		Indicates the accumulated hours of drum running time. The cursor (▶) cannot be aligned with this item.

99

TROUBLESHOOTING Alarm Indications and Actions

The GY-DV300 displays messages in the case of improper operation, notices on remaining battery power and tape and warnings in the case of abnormalities during VTR operation on the LCD screen and in the viewfinder.

The TALLY lamp also blinks when the remaining battery power or tape becomes low.

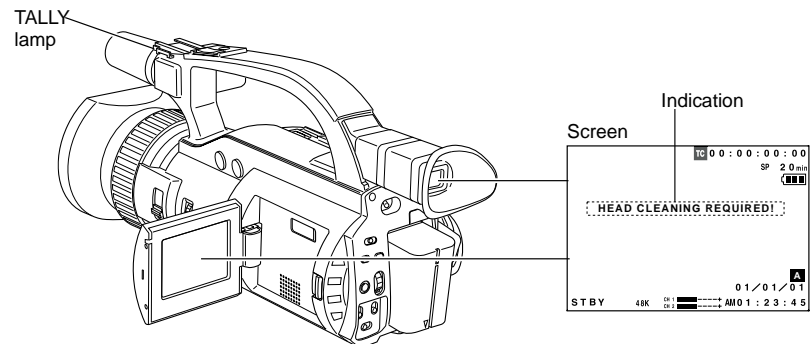

■ Indications on the LCD screen/Viewfinder screen

● Improper operation and notices

Indication	Condition	Remedy
CLOSE CASSETTE COVER!	The cassette cover is open. The GY-DV300 does not operate when the cassette cover is open.	Close the cassette cover.
NO TAPE	Displayed when no videocassette is loaded.	Insert a videocassette.
REC INHIBIT	Displayed when an unrecordable videocassette (the switch on the back of the cassette is set to "SAVE") is loaded.	Set the switch on the back of the cassette is set to "REC".
1394 INHIBIT (U MODEL)	Displayed if an attempt to record is made when no DV signal is input.	Input the DV signal.
COPY INHIBIT	Displayed when attempt to record a copy-guard protected signal is made.	A copy-guard protected signal cannot be recorded.
LOW VOLTAGE	Displayed when remaining battery power becomes low.	Prepare a charged battery or replace the battery immediately.
TAPE NEAR END	The remaining tape is 3 minutes or less. (Only displayed in the shooting mode.)	To continue the recording, prepare a new tape or replace with a new tape immediately.
TAPE END	Displayed when the tape has run out.	
TAPE BEGIN	Displayed when the tape is at beginning position	
CASSETTE COVER OPEND!	Displayed when the cassette cover was opened during recording.	
CASS.CARRIAGE UNLOCK	Displayed when the cassette cover is closed but the cassette holder is not locked.	Lock the cassette holder correctly.

TENTATIVE

100

● **WARNINGS**

Indication	Condition	VTR operation and remedy
HEAD CLEANING REQUIRED!	Displayed in case of video head clogging. (Head clogging is detected and indicated during edit search in the recording mode and during playback.)	Operation : Continues Remedy : Clean the head with the special head cleaning tape. (☞ See page 10.)
VTR WARNING (DEW)	Displayed when condensation occurs in the GY-DV300.	Operation : Attempts to operate are rejected. Remedy : Leave the GY-DV300 with the power turned ON until the indication disappears.
VTR WARNING (HARD)	Displayed when abnormality occurs in the GY-DV300.	Operation : Operation stops. All attempts to operate are rejected. Remedy : This condition can be cancelled by setting the POWER switch to "OFF" and then back to "ON" again. In some cases, however, the tape may be damaged. Please consult the person in charge of professional video equipment at your nearest JVC-authorized service agent.
VTR WARNING (TAPE)	The tape is cut.	Operation : Operation stops. Remedy : Take out the cassette tape.

■ **TALLY lamp**

This lamp blinks when the remaining battery voltage becomes low or the remaining tape is near end. (In shooting mode only)

Blinking Condition	Remaining Battery/Tape
Slow blinking (1 time per sec)	<ul style="list-style-type: none"> No more remaining battery power. Remaining tape time is 3 minutes or less.
Fast blinking (4 timer per sec)	<ul style="list-style-type: none"> Tape has run out. Abnormality in VTR.

Memo:

The GY-DV300 is a microcomputer-controlled piece of equipment, which may malfunction due to external noise or interference. In this case, turn the power OFF, and then turn it ON again.

TROUBLESHOOTING In Case of Difficulty

Symptoms	Troubles, Checks and Remedial Actions
Power cannot be switched ON.	<ul style="list-style-type: none"> Is power supply connected properly? Is battery pack charged? Was the power turned ON immediately after being turned OFF? Wait at least 5 seconds before turning the power ON again once it has been turned OFF.
Operation buttons on the GY-DV300 fail to work.	<ul style="list-style-type: none"> Is the cassette cover open? The GY-DV300 remains inoperative as long as the cassette door is open. Is a tape inserted?
Recording is not possible.	<ul style="list-style-type: none"> Is the switch on cassette set to "REC"? If it is set to "SAVE", set it to REC. Is the MODE switch set to "CAM-A" or "CAM-B"? If set to "VTR", shooting of camera is not possible.
The camera image does not appear on the LCD screen or in the viewfinder.	<ul style="list-style-type: none"> Is the MODE switch set to "CAM-A" or "CAM-B"? If set to "VTR", the camera image is not output.
Image on the LCD screen or the viewfinder screen looks dark or unclear.	<ul style="list-style-type: none"> Adjust the brightness of the LCD screen or viewfinder screen. Check if the ND filter switch is set to "ON". Is the iris closed? Is the shutter speed setting too fast?
Manual adjustments, such as adjustment of shutter speed, gain, iris, etc. not possible.	<ul style="list-style-type: none"> Is the shooting mode the AUTO mode? Is AE mode ON? To enable manual adjustments, set the AE item on the OPERATION menu screen to OFF.
Camera-shake compensation does not work.	<ul style="list-style-type: none"> Is the OIS item on the OPERATION menu screen set to OFF? Set to ON to activate the camera-shake compensation function.
The sound from the built-in microphone is not input.	<ul style="list-style-type: none"> Is the MIC1 INPUT SEL item on the SYSTEM [1/2] menu screen set to XLR? To use the built-in microphone, set to INT.
The sound from the microphone connected to the MIC 1 input connector is not input.	<ul style="list-style-type: none"> Is the MIC1 INPUT SEL item on the SYSTEM [1/2] menu screen set to INT? To use the microphone connected to the MIC 1 input connector, set to XLR.
Noise interferes with playback video.	<ul style="list-style-type: none"> Video head may be clogged with dirt. Clean head with the special head cleaning tape. (☞ See page 10.)
Noise appears when playing back a tape recorded on another unit.	<ul style="list-style-type: none"> When a tape recorded on another unit is played back or used for recording, this phenomenon may occur due to tracking errors.
The transient section between scenes recorded on other units and those recorded on the GY-DV300 may appear disturbed.	
Sound is not heard from the built-in speaker in the recording mode.	<ul style="list-style-type: none"> Sound is not output from the built-in speaker in the recording mode. The built-in speaker outputs the playback sound.
No sound during playback.	<ul style="list-style-type: none"> Is the PB AUDIO SEL item on the VTR menu screen set to CH3/4? To output the sound recorded during shooting, set to CH1/CH2.

Symptoms	Troubles, Checks and Remedial Actions
Mosaic-type noise appears during search.	<ul style="list-style-type: none"> This is a phenomenon caused by the digital characteristics. This is not a malfunction.
Playback does not start even if the playback button is pressed.	<ul style="list-style-type: none"> Is the MODE switch set to "VTR"? Playback is not possible if the switch is set to "CAM-A" or "CAM-B".
DV signal input not possible.	<ul style="list-style-type: none"> Is the MODE switch set to "VTR"? Input of DV signal is not possible if the switch is set to "CAM-A" or "CAM-B". (U MODEL) The GY-DV300 is not capable of recording DV signals. (U MODEL)
Cassette cannot be ejected after the power is turned ON.	<ul style="list-style-type: none"> The capacity of the power supply may be insufficient. Check the power voltage.

OTHERS Displaying the Hour Meter Display

The GY-DV300 indicates the accumulated hours of drum running time by means of the HOUR METER displayed on the LCD screen or viewfinder screen. Display of the HOUR METER is selected by the DRUM HOUR item on the VTR menu screen. This is used as yardstick for periodical maintenance. (☞ See page 9.)

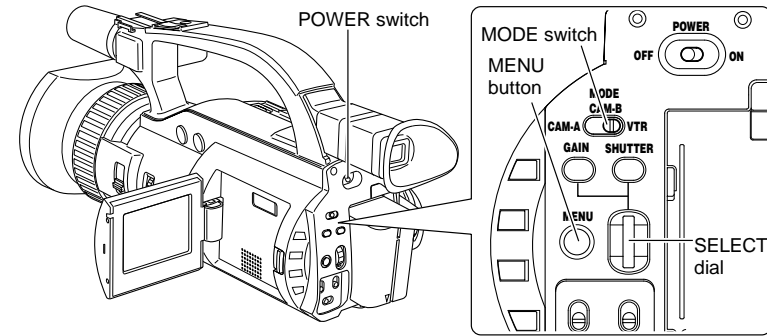

TOP MENU screen

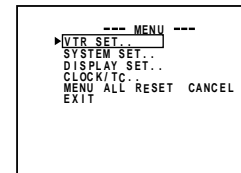

VTR menu screen

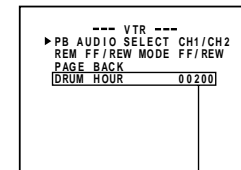

Indicates accumulated drum running time

1. Set the POWER switch to "ON".
 2. Set the MODE switch to "VTR".
 3. Press the MENU button to display the TOP MENU screen.
 4. Rotate the SELECT dial to align the cursor (▶) with the VTR SET item, and then press the SELECT dial.
 - The VTR menu screen is displayed.
- The accumulated drum running time is indicated after the DRUM HOUR item on the VTR menu screen.
5. To return to the normal screen, use either of the following methods.
 - Press the MENU button
 - or
 - Return to the TOP MENU screen and then select the EXIT item from the TOP MENU screen before pressing the SELECT dial.

U OTHERS Specifications

■ CAMERA SECTION

Image pickup devices : 1/3-inch interline CCD × 3

Color separation optical system :

F1.6 3-color separation prism

Number of effective pixels :

380,000 pixels ((H) 768 × (V) 492)

Color system : NTSC (wide-band R-Y, B-Y encoder)

Color bars : SMPTE standard color bar

Sync system : Internal sync (built-in SSG)

Lens magnification : 14X (optical)

Optical filter : 1/32 ND built-n

Sensitivity : F11, 2000 lx

Minimum illumination :

2.65 lx (F1.6, LOLUX mode) Calculated value

Gain : -3 dB to 18 dB (1 dB step) ALC, LOLUX

Electronic shutter speed :

1/100, 1/250, 1/500, 1/1000, 1/2000

Variable scan speed : 60.1 Hz to 2084.6 Hz

Contour correction : Horizontal: dual-edged. Vertical: dual-edged

■ LENS SECTION

Focal length : f = 5.7 mm - 79.8 mm

Max. aperture : 1:1.6 (WIDE) - 1:2.8 (TELE)

Minimum distance to subject :

1.0 m (full zoom range)

Camera-shake compensation range :

±0.3 degrees

[VTR SECTION]

Recording format : DV format SD specification

Format : MiniDV

Tape speed : 18.812 mm/sec (SP mode), 12.555 mm/s (LP mode)

Record/Play time : 60 minutes (With M-DV60ME cassette, SP Mode)

90 minutes (With M-DV60ME cassette, LP Mode)

F.F/Rewind time : Approx. 2 minutes (With M-DV60ME cassette)

[VIDEO SIGNAL SYSTEM]

Recording format : 8-bit, 13.5 MHz, 4:1:1 component recording

[AUDIO SIGNAL SYSTEM]

Recording format : 16-bit, 48 kHz, 2-channel PCM audio/12-bit, 32 kHz 4-channel PCM audio (recording only 2 channels)

Frequency response : 50 Hz to 20 kHz (in 48 kHz mode)

■ INPUT/OUTPUT SIGNALS

Video signal output : 1 V (p-p), 75 ohms unbalanced composite output. (BNC)

YC output : Y 1 V (p-p) 75 ohms unbalance
C 0.286 V (p-p) 75 ohms unbalance (4P)

Microphone input : -60 dBs, 3 kohms balanced, phantom power supply +48 V output supported (XLR 3-P, 2 systems)

Audio output : -8 dBs, 1 kohms, unbalanced (RCA)

Earphone output : -60 dBs to -28 dBs, at 8-ohm load (monaural mini-jack)

DV connector : 4P

DC input : 6V to 12V DC

Built-in microphone : Unidirectional, sensitivity -40 dBs

TENTATIVE

E OTHERS Specifications

■ CAMERA SECTION

Image pickup devices : 1/3-inch interline CCD × 3

Colour separation optical system :

F1.6 3-colour separation prism

Number of effective pixels :

440,000 pixels ((H) 752 × (V) 582)

Colour system : PAL (wide-band R-Y, B-Y encoder)

Colour bars : EBU standard colour bar

Sync system : Internal sync (built-in SSG)

Lens magnification : 14X (optical)

Optical filter : 1/32 ND built-n

Sensitivity : F11, 2000 lx

Minimum illumination :

2.65 lx (F1.6, LOLUX mode) Calculated value

Gain : -3 dB to 18 dB (1 dB step), ALC, LOLUX

Electronic shutter speed :

1/120, 1/250, 1/500, 1/1000, 1/2000

Variable scan speed : 50.1 Hz to 2067.8 Hz

Contour correction : Horizontal: dual-edged. Vertical: dual-edged

■ LENS SECTION

Focal length : f = 5.7 mm - 79.8 mm

Max. aperture : 1:1.6 (WIDE) - 1:2.8 (TELE)

Minimum distance to subject :

1.0 m (full zoom range)

Camera-shake compensation range :

±0.3 degrees

[VTR SECTION]

Recording format : DV format SD specification

Format : MiniDV

Tape speed : 18.831 mm/sec (SP mode), 12.568 mm/s (LP mode)

mode)

Record/Play time : 60 minutes (With M-DV60ME cassette, SP Mode)

90 minutes (With M-DV60ME cassette, LP Mode)

F.F/Rewind time : Approx. 2 minutes (With M-DV60ME cassette)

[VIDEO SIGNAL SYSTEM]

Recording format : 8-bit, 13.5 MHz, 4:2:0 component recording

[AUDIO SIGNAL SYSTEM]

Recording format : 16-bit, 48 kHz, 2-channel PCM audio/12-bit, 32 kHz 4-channel PCM audio (recording only 2 channels)

Frequency response : 50 Hz to 20 kHz (in 48 kHz mode)

■ INPUT/OUTPUT SIGNALS

Video signal output : 1 V (p-p), 75 ohms unbalanced composite output. (BNC)

YC output : Y 1 V (p-p) 75 ohms unbalance
C 0.3 V (p-p) 75 ohms unbalance (4P)

Microphone input : -60 dBs, 3 kohms balanced, phantom power supply +48 V output supported (XLR 3-P, 2 systems)

Audio output : -8 dBs, 1 kohms, unbalanced (RCA)

Earphone output : -60 dBs to -28 dBs, at 8-ohm load (monaural mini-jack)

DV connector : 4P

DC input : 6V to 12V DC

Built-in microphone : Unidirectional, sensitivity -40 dBs

U OTHERS Specifications (cont'd)

■ GENERAL

Power consumption : DC7.2 V ≐ 14.4 W

Mass : Approx. 1.4 kg
(without battery)

Allowable operating temperatures :
0 °C to 40 °C

Allowable operating humidity :
30% to 80% RH

Allowable storage temperatures :
-20 °C to 60 °C

■ ACCESSORIES

Instruction Manual : x 1

Battery Pack : BN-V428

AC power adapter (battery pack charger) :
AA-P30

■ OPTIONAL ACCESSORIES

Microphone : MV-P615U

Microphone holder : KA-A33

Network pack : KA-DV300

DV cable : VX-DV130 (4P-4P)
VX-DV230 (4P-6P)

Design and specifications are subject to change without notice.

E OTHERS Specifications (cont'd)

■ GENERAL

Power consumption : 7.2 V ≐ 2.0A

Mass : Approx. 1.4 kg (without
battery)

Allowable operating temperatures :
0 °C to 40 °C

Allowable operating humidity :
30% to 80% RH

Allowable storage temperatures :
-20 °C to 60 °C

■ ACCESSORIES

Instruction Manual : x 1

■ OPTIONAL ACCESSORIES

Battery Pack : BN-V416, BN-V428

AC power adapter (battery pack charger) :
AA-P30

Microphone : MV-P615U

Microphone holder : KA-A33

Network pack : KA-DV300

DV cable : VX-DV130 (4P-4P)
VX-DV230 (4P-6P)

Design and specifications are subject to change without notice.

TENTATIVE

■ EXTERNAL DIMENSIONS (unit: mm)

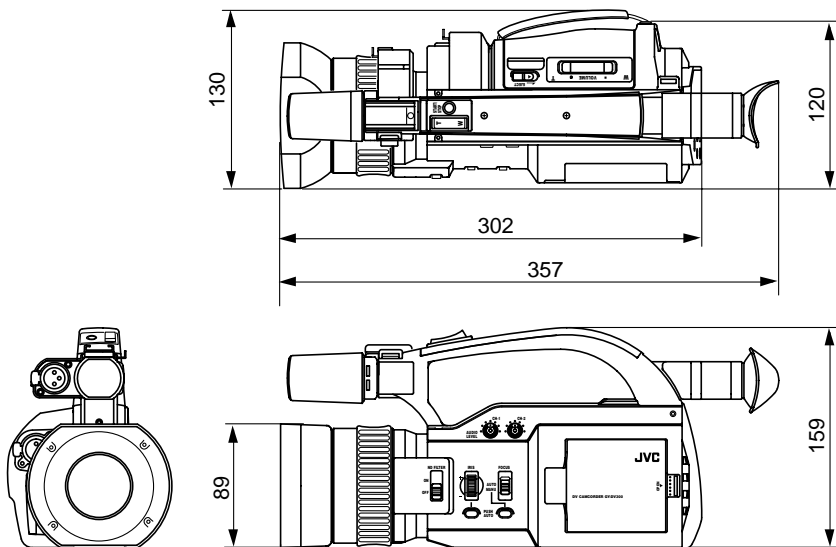

JVC[®]
VICTOR COMPANY OF JAPAN, LIMITED

JVC[®] is a registered trademark owned by VICTOR COMPANY OF JAPAN, LTD.
JVC[®] is a registered trademark in Japan, the U.S.A., the U.K. and many other countries.
© 2002 VICTOR COMPANY OF JAPAN, LIMITED

 Printed in Japan
LWT0017 (U MODEL)
LWT0018 (E MODEL)